



Microeconomics III: Problem Set 11^a

Thor Donsby Noe (thor.noe@econ.ku.dk) & Christopher Borberg (christopher.borberg@econ.ku.dk)
April 14 2020

Department of Economics, University of Copenhagen

^aSlides created for exercise class with reservation for possible errors.

Outline

PS11, Ex. 1 (A): Signaling effect of the GED education program

PS11, Ex. 2 (A): Asymmetric/incomplete information (PBE)

Signaling games in general

PS11, Ex. 3: Signaling game (pooling and separating PBE)

PS11, Ex. 3.a: Signaling game (pooling PBE)

PS11, Ex. 3.b: Signaling game (separating PBE)

PS11, Ex. 4: Signaling games (pooling and separating PBE)

PS11, Ex. 4.a: Signaling game (pooling and separating PBE)

PS11, Ex. 4.b: Signaling game (pooling and separating PBE)

PS11, Ex. 5: Signaling games (pooling PBE)

PS11, Ex. 5.a: Signaling game (pooling PBE)

PS11, Ex. 5.b: Three-type signaling game (pooling PBE)

PS11, Ex. 6: Spence's education signaling model (pooling and separating PBE)

PS11, Ex. 6.a: Spence's education signaling model (separating PBE)

PS11, Ex. 6.b: Spence's education signaling model (pooling PBE)

**PS11, Ex. 1 (A): Signaling effect of
the GED education program**

PS11, Ex. 1 (A): Signaling effect of the GED education program

Does signaling work? Read the article by Tyler, Murnane and Willett and think about their results. What is their hypothesis for why they do not find an effect for minority groups? Come up with an example of an education program that has mostly signaling value in your country.

(This is a reflection question, no answer will be provided).

PS11, Ex. 2 (A):
Asymmetric/incomplete information
(PBE)

Exercise 4.11 in Gibbons (p. 250). Difficult. A buyer and a seller have valuations v_b and v_s . It is common knowledge that there are gains from trade (i.e., that $v_b > v_s$), but the size of the gains is private information, as follows: the seller's valuation is uniformly distributed on $[0,1]$; the buyer's valuation $v_b = kv_s$, where $k > 1$ is common knowledge; the seller knows v_s (and hence v_b) but the buyer does not know v_b (and hence v_s). Suppose the buyer makes a single offer, p , which the seller either accepts or rejects. What is the perfect Bayesian equilibrium when $k < 2$? When $k > 2$? (See Samuelson 1984.)

PS11, Ex. 2 (A): Asymmetric/incomplete information (PBE)

Exercise 4.11 in Gibbons (p. 250). Difficult. A buyer and a seller have valuations v_b and v_s . It is common knowledge that there are gains from trade (i.e., that $v_b > v_s$), but the size of the gains is private information, as follows: the seller's valuation is uniformly distributed on $[0,1]$; the buyer's valuation $v_b = kv_s$, where $k > 1$ is common knowledge; the seller knows v_s (and hence v_b) but the buyer does not know v_b (and hence v_s). Suppose the buyer makes a single offer, p , which the seller either accepts or rejects. What is the perfect Bayesian equilibrium when $k < 2$? When $k > 2$? (See Samuelson 1984.)

Step 1: **Consider the uniform distribution $x \sim U(a, b)$. Use the cumulative distribution function (CDF) to write up the probability that a random draw of x is lower than a constant c . Use the mean to write up the expected value of a random draw of x where x is lower than a constant $c \in [a, b]$.**

PS11, Ex. 2 (A): Asymmetric/incomplete information (PBE)

Exercise 4.11 in Gibbons (p. 250). Difficult. A buyer and a seller have valuations v_b and v_s . It is common knowledge that there are gains from trade (i.e., that $v_b > v_s$), but the size of the gains is private information, as follows: the seller's valuation is uniformly distributed on $[0,1]$; the buyer's valuation $v_b = kv_s$, where $k > 1$ is common knowledge; the seller knows v_s (and hence v_b) but the buyer does not know v_b (and hence v_s). Suppose the buyer makes a single offer, p , which the seller either accepts or rejects. What is the perfect Bayesian equilibrium when $k < 2$? When $k > 2$? (See Samuelson 1984.)

Step 1: Consider the uniform distribution $x \sim U(a, b)$. Use the cumulative distribution function (CDF) to write up the probability that a random draw of x is lower than a constant c . Use the mean to write up the expected value of a random draw of x where x is lower than a constant $c \in [a, b]$.

1. Standard results for $x \sim U(a, b)$:

$$\text{CDF: } F(x) = \frac{x-a}{b-a} \Rightarrow \mathbb{P}(x < c) = \frac{c-a}{b-a} \quad (\dagger)$$

$$\text{Mean: } \mu = \frac{a+b}{2} \Rightarrow \mathbb{E}(x < c) = \frac{a+c}{2} \quad (\ddagger)$$

PS11, Ex. 2 (A): Asymmetric/incomplete information (PBE)

Exercise 4.11 in Gibbons (p. 250). Difficult. A buyer and a seller have valuations v_b and v_s . It is common knowledge that there are gains from trade (i.e., that $v_b > v_s$), but the size of the gains is private information, as follows: the seller's valuation is uniformly distributed on $[0,1]$; the buyer's valuation $v_b = kv_s$, where $k > 1$ is common knowledge; the seller knows v_s (and hence v_b) but the buyer does not know v_b (and hence v_s). Suppose the buyer makes a single offer, p , which the seller either accepts or rejects. What is the perfect Bayesian equilibrium when $k < 2$? When $k > 2$? (See Samuelson 1984.)

Step 1: Consider the uniform distribution $x \sim U(a, b)$. Use the cumulative distribution function (CDF) to write up the probability that a random draw of x is lower than a constant c . Use the mean to write up the expected value of a random draw of x where x is lower than a constant $c \in [a, b]$.

Step 2: **The buyer offers a price p . Write up the seller's strategy (best response).**

1. Standard results for $x \sim U(a, b)$:

$$\text{CDF: } F(x) = \frac{x-a}{b-a} \Rightarrow \mathbb{P}(x < c) = \frac{c-a}{b-a} \quad (\dagger)$$

$$\text{Mean: } \mu = \frac{a+b}{2} \Rightarrow \mathbb{E}(x < c) = \frac{a+c}{2} \quad (\ddagger)$$

PS11, Ex. 2 (A): Asymmetric/incomplete information (PBE)

Exercise 4.11 in Gibbons (p. 250). Difficult. A buyer and a seller have valuations v_b and v_s . It is common knowledge that there are gains from trade (i.e., that $v_b > v_s$), but the size of the gains is private information, as follows: the seller's valuation is uniformly distributed on $[0,1]$; the buyer's valuation $v_b = kv_s$, where $k > 1$ is common knowledge; the seller knows v_s (and hence v_b) but the buyer does not know v_b (and hence v_s). Suppose the buyer makes a single offer, p , which the seller either accepts or rejects. What is the perfect Bayesian equilibrium when $k < 2$? When $k > 2$? (See Samuelson 1984.)

Step 1: Consider the uniform distribution $x \sim U(a, b)$. Use the cumulative distribution function (CDF) to write up the probability that a random draw of x is lower than a constant c . Use the mean to write up the expected value of a random draw of x where x is lower than a constant $c \in [a, b]$.

Step 2: The buyer offers a price p . Write up the seller's strategy (best response).

1. Standard results for $x \sim U(a, b)$:

$$\text{CDF: } F(x) = \frac{x-a}{b-a} \Rightarrow \mathbb{P}(x < c) = \frac{c-a}{b-a} \quad (\dagger)$$

$$\text{Mean: } \mu = \frac{a+b}{2} \Rightarrow \mathbb{E}(x < c) = \frac{a+c}{2} \quad (\ddagger)$$

$$2. S_s(p, v_s) = \begin{cases} \text{Sell} & \text{if } p \geq v_s \\ \text{Don't} & \text{if } p < v_s \end{cases}$$

PS11, Ex. 2 (A): Asymmetric/incomplete information (PBE)

Exercise 4.11 in Gibbons (p. 250). Difficult. A buyer and a seller have valuations v_b and v_s . It is common knowledge that there are gains from trade (i.e., that $v_b > v_s$), but the size of the gains is private information, as follows: the seller's valuation is uniformly distributed on $[0,1]$; the buyer's valuation $v_b = kv_s$, where $k > 1$ is common knowledge; the seller knows v_s (and hence v_b) but the buyer does not know v_b (and hence v_s). Suppose the buyer makes a single offer, p , which the seller either accepts or rejects. What is the perfect Bayesian equilibrium when $k < 2$? When $k > 2$? (See Samuelson 1984.)

Step 1: Consider the uniform distribution $x \sim U(a, b)$. Use the cumulative distribution function (CDF) to write up the probability that a random draw of x is lower than a constant c . Use the mean to write up the expected value of a random draw of x where x is lower than a constant $c \in [a, b]$.

Step 2: The buyer offers a price p . Write up the seller's strategy (best response).

Step 3: **Write out the buyer's problem.**

1. Standard results for $x \sim U(a, b)$:

$$\text{CDF: } F(x) = \frac{x-a}{b-a} \Rightarrow \mathbb{P}(x < c) = \frac{c-a}{b-a} \quad (\dagger)$$

$$\text{Mean: } \mu = \frac{a+b}{2} \Rightarrow \mathbb{E}(x < c) = \frac{a+c}{2} \quad (\ddagger)$$

$$2. S_s(p, v_s) = \begin{cases} \text{Sell} & \text{if } p \geq v_s \\ \text{Don't} & \text{if } p < v_s \end{cases}$$

PS11, Ex. 2 (A): Asymmetric/incomplete information (PBE)

Exercise 4.11 in Gibbons (p. 250). Difficult. A buyer and a seller have valuations v_b and v_s . It is common knowledge that there are gains from trade (i.e., that $v_b > v_s$), but the size of the gains is private information, as follows: the seller's valuation is uniformly distributed on $[0,1]$; the buyer's valuation $v_b = kv_s$, where $k > 1$ is common knowledge; the seller knows v_s (and hence v_b) but the buyer does not know v_b (and hence v_s). Suppose the buyer makes a single offer, p , which the seller either accepts or rejects. What is the perfect Bayesian equilibrium when $k < 2$? When $k > 2$? (See Samuelson 1984.)

Step 1: Consider the uniform distribution $x \sim U(a, b)$. Use the cumulative distribution function (CDF) to write up the probability that a random draw of x is lower than a constant c . Use the mean to write up the expected value of a random draw of x where x is lower than a constant $c \in [a, b]$.

Step 2: The buyer offers a price p . Write up the seller's strategy (best response).

Step 3: Write out the buyer's problem:

$$\max_p \mathbb{P}[v_s < p] \mathbb{E}[v_b - p | v_s < p]$$

1. Standard results for $x \sim U(a, b)$:

$$\text{CDF: } F(x) = \frac{x-a}{b-a} \Rightarrow \mathbb{P}(x < c) = \frac{c-a}{b-a} \quad (\dagger)$$

$$\text{Mean: } \mu = \frac{a+b}{2} \Rightarrow \mathbb{E}(x < c) = \frac{a+c}{2} \quad (\ddagger)$$

$$2. S_s(p, v_s) = \begin{cases} \text{Sell} & \text{if } p \geq v_s \\ \text{Don't} & \text{if } p < v_s \end{cases}$$

PS11, Ex. 2 (A): Asymmetric/incomplete information (PBE)

Exercise 4.11 in Gibbons (p. 250). Difficult. A buyer and a seller have valuations v_b and v_s . It is common knowledge that there are gains from trade (i.e., that $v_b > v_s$), but the size of the gains is private information, as follows: the seller's valuation is uniformly distributed on $[0,1]$; the buyer's valuation $v_b = kv_s$, where $k > 1$ is common knowledge; the seller knows v_s (and hence v_b) but the buyer does not know v_b (and hence v_s). Suppose the buyer makes a single offer, p , which the seller either accepts or rejects. What is the perfect Bayesian equilibrium when $k < 2$? When $k > 2$? (See Samuelson 1984.)

Step 1: Use the CDF to write up $\mathbb{P}(x < c)$.

Use the mean to write up $\mathbb{E}(x < c)$.

Step 2: The buyer offers a price p . Write up the seller's strategy (best response).

Step 3: Write out the buyer's problem:

$$\max_p \mathbb{P}[v_s < p] \mathbb{E}[v_b - p | v_s < p]$$

$$= \max_p \frac{p-0}{1-0} \mathbb{E}[kv_s - p | v_s < p]$$

$$= \max_p p (k \mathbb{E}[v_s < p] - p)$$

$$= \max_p p \left(k \frac{0+p}{2} - p \right)$$

$$\text{using } (\dagger) \quad 3. \max_p u_b(p) = \max_p p^2 \left(\frac{k}{2} - 1 \right)$$

$$\text{using } (\ddagger)$$

1. Standard results for $x \sim U(a, b)$:

$$\text{CDF: } F(x) = \frac{x-a}{b-a} \Rightarrow \mathbb{P}(x < c) = \frac{c-a}{b-a} \quad (\dagger)$$

$$\text{Mean: } \mu = \frac{a+b}{2} \Rightarrow \mathbb{E}(x < c) = \frac{a+c}{2} \quad (\ddagger)$$

$$2. S_s(p, v_s) = \begin{cases} \text{Sell} & \text{if } p \geq v_s \\ \text{Don't} & \text{if } p < v_s \end{cases}$$

PS11, Ex. 2 (A): Asymmetric/incomplete information (PBE)

Exercise 4.11 in Gibbons (p. 250). Difficult. A buyer and a seller have valuations v_b and v_s . It is common knowledge that there are gains from trade (i.e., that $v_b > v_s$), but the size of the gains is private information, as follows: the seller's valuation is uniformly distributed on $[0,1]$; the buyer's valuation $v_b = kv_s$, where $k > 1$ is common knowledge; the seller knows v_s (and hence v_b) but the buyer does not know v_b (and hence v_s). Suppose the buyer makes a single offer, p , which the seller either accepts or rejects. What is the perfect Bayesian equilibrium when $k < 2$? When $k > 2$? (See Samuelson 1984.)

Step 1: Use the CDF to write up $\mathbb{P}(x < c)$.

Use the mean to write up $\mathbb{E}(x < c)$.

Step 2: The buyer offers a price p . Write up the seller's strategy (best response).

Step 3: Write out the buyer's problem:

$$\max_p \mathbb{P}[v_s < p] \mathbb{E}[v_b - p | v_s < p]$$

$$= \max_p \frac{p-0}{1-0} \mathbb{E}[kv_s - p | v_s < p] \quad \text{using } (\dagger)$$

$$= \max_p p(k\mathbb{E}[v_s < p] - p)$$

$$= \max_p p \left(k \frac{0+p}{2} - p \right) \quad \text{using } (\ddagger)$$

1. Standard results for $x \sim U(a, b)$:

$$\text{CDF: } F(x) = \frac{x-a}{b-a} \Rightarrow \mathbb{P}(x < c) = \frac{c-a}{b-a} \quad (\dagger)$$

$$\text{Mean: } \mu = \frac{a+b}{2} \Rightarrow \mathbb{E}(x < c) = \frac{a+c}{2} \quad (\ddagger)$$

$$2. S_s(p, v_s) = \begin{cases} \text{Sell} & \text{if } p \geq v_s \\ \text{Don't} & \text{if } p < v_s \end{cases}$$

$$3. \max_p u_b(p) = \max_p p^2 \left(\frac{k}{2} - 1 \right)$$

Step 4: Take the first-order condition wrt p

PS11, Ex. 2 (A): Asymmetric/incomplete information (PBE)

Exercise 4.11 in Gibbons (p. 250). Difficult. A buyer and a seller have valuations v_b and v_s . It is common knowledge that there are gains from trade (i.e., that $v_b > v_s$), but the size of the gains is private information, as follows: the seller's valuation is uniformly distributed on $[0,1]$; the buyer's valuation $v_b = kv_s$, where $k > 1$ is common knowledge; the seller knows v_s (and hence v_b) but the buyer does not know v_b (and hence v_s). Suppose the buyer makes a single offer, p , which the seller either accepts or rejects. What is the perfect Bayesian equilibrium when $k < 2$? When $k > 2$? (See Samuelson 1984.)

Step 1: Use the CDF to write up $\mathbb{P}(x < c)$.

Use the mean to write up $\mathbb{E}(x < c)$.

Step 2: The buyer offers a price p . Write up the seller's strategy (best response).

Step 3: Write out the buyer's problem.

Step 4: Take the first-order condition wrt. p :

$$\frac{\delta u_b(p)}{\delta p} = 0$$

$$2p \left(\frac{k}{2} - 1 \right) = 0 \quad \text{(take the SOC)}$$

$$2p \frac{k}{2} = 2p$$

$$p \frac{k}{2} = p$$

1. Standard results for $x \sim U(a, b)$:

$$\text{CDF: } F(x) = \frac{x-a}{b-a} \Rightarrow \mathbb{P}(x < c) = \frac{c-a}{b-a} \quad (\ddagger)$$

$$\text{Mean: } \mu = \frac{a+b}{2} \Rightarrow \mathbb{E}(x < c) = \frac{a+c}{2} \quad (\ddagger)$$

$$2. S_s(p, v_s) = \begin{cases} \text{Sell} & \text{if } p \geq v_s \\ \text{Don't} & \text{if } p < v_s \end{cases}$$

$$3. \max_p u_b(p) = \max_p p^2 \left(\frac{k}{2} - 1 \right)$$

$$4. \text{FOC: } p \frac{k}{2} = p$$

SOC: What is the functional form of $u_b(p)$ for different values of k ? E.g. is the buyer's utility a linear, concave, or convex function of p ?

PS11, Ex. 2 (A): Asymmetric/incomplete information (PBE)

Exercise 4.11 in Gibbons (p. 250). Difficult. A buyer and a seller have valuations v_b and v_s . It is common knowledge that there are gains from trade (i.e., that $v_b > v_s$), but the size of the gains is private information, as follows: the seller's valuation is uniformly distributed on $[0,1]$; the buyer's valuation $v_b = kv_s$, where $k > 1$ is common knowledge; the seller knows v_s (and hence v_b) but the buyer does not know v_b (and hence v_s). Suppose the buyer makes a single offer, p , which the seller either accepts or rejects. What is the perfect Bayesian equilibrium when $k < 2$? When $k > 2$? (See Samuelson 1984.)

Step 1: Use the CDF to write up $\mathbb{P}(x < c)$.

Use the mean to write up $\mathbb{E}(x < c)$.

Step 2: The buyer offers a price p . Write up the seller's strategy (best response).

Step 3: Write out the buyer's problem.

Step 4: Take the first-order condition wrt. p :

$$\frac{\delta u_b(p)}{\delta p} = 0$$

$$2p \left(\frac{k}{2} - 1 \right) = 0 \quad (\text{take the SOC})$$

$$2p \frac{k}{2} = 2p$$

$$p \frac{k}{2} = p$$

1. Standard results for $x \sim U(a, b)$:

$$\text{CDF: } F(x) = \frac{x-a}{b-a} \Rightarrow \mathbb{P}(x < c) = \frac{c-a}{b-a} \quad (\dagger)$$

$$\text{Mean: } \mu = \frac{a+b}{2} \Rightarrow \mathbb{E}(x < c) = \frac{a+c}{2} \quad (\ddagger)$$

$$2. S_s(p, v_s) = \begin{cases} \text{Sell} & \text{if } p \geq v_s \\ \text{Don't} & \text{if } p < v_s \end{cases}$$

$$3. \max_p u_b(p) = \max_p p^2 \left(\frac{k}{2} - 1 \right)$$

$$4. \text{FOC: } p \frac{k}{2} = p$$

$$\text{SOC: } k - 2 \begin{cases} < 0, & k \in (1, 2) & \Rightarrow \text{concave} \\ = 0, & k = 2 & \Rightarrow \text{flat} \\ > 0, & k > 2 & \Rightarrow \text{convex} \end{cases}$$

PS11, Ex. 2 (A): Asymmetric/incomplete information (PBE)

Exercise 4.11 in Gibbons (p. 250). Difficult. A buyer and a seller have valuations v_b and v_s . It is common knowledge that there are gains from trade (i.e., that $v_b > v_s$), but the size of the gains is private information, as follows: the seller's valuation is uniformly distributed on $[0,1]$; the buyer's valuation $v_b = kv_s$, where $k > 1$ is common knowledge; the seller knows v_s (and hence v_b) but the buyer does not know v_b (and hence v_s). Suppose the buyer makes a single offer, p , which the seller either accepts or rejects. What is the perfect Bayesian equilibrium when $k < 2$? When $k > 2$? (See Samuelson 1984.)

Step 1: Use the CDF to write up $\mathbb{P}(x < c)$.

Use the mean to write up $\mathbb{E}(x < c)$.

Step 2: The buyer offers a price p . Write up the seller's strategy (best response).

Step 3: Write out the buyer's problem.

Step 4: Take the first-order and second-order condition wrt. p .

Step 5: **Maximize buyer's utility for $k < 2$.**

1. Standard results for $x \sim U(a, b)$:

$$\text{CDF: } F(x) = \frac{x-a}{b-a} \Rightarrow \mathbb{P}(x < c) = \frac{c-a}{b-a} \quad (\dagger)$$

$$\text{Mean: } \mu = \frac{a+b}{2} \Rightarrow \mathbb{E}(x < c) = \frac{a+c}{2} \quad (\ddagger)$$

$$2. S_s(p, v_s) = \begin{cases} \text{Sell} & \text{if } p \geq v_s \\ \text{Don't} & \text{if } p < v_s \end{cases}$$

$$3. \max_p u_b(p) = \max_p p^2 \left(\frac{k}{2} - 1 \right)$$

$$4. \text{FOC: } p \frac{k}{2} = p$$

$$\text{SOC: } k - 2 \begin{cases} < 0, & k \in (1, 2) & \Rightarrow \text{concave} \\ = 0, & k = 2 & \Rightarrow \text{flat} \\ > 0, & k > 2 & \Rightarrow \text{convex} \end{cases}$$

PS11, Ex. 2 (A): Asymmetric/incomplete information (PBE)

Exercise 4.11 in Gibbons (p. 250). Difficult. A buyer and a seller have valuations v_b and v_s . It is common knowledge that there are gains from trade (i.e., that $v_b > v_s$), but the size of the gains is private information, as follows: the seller's valuation is uniformly distributed on $[0,1]$; the buyer's valuation $v_b = kv_s$, where $k > 1$ is common knowledge; the seller knows v_s (and hence v_b) but the buyer does not know v_b (and hence v_s). Suppose the buyer makes a single offer, p , which the seller either accepts or rejects. What is the perfect Bayesian equilibrium when $k < 2$? When $k > 2$? (See Samuelson 1984.)

Step 1: Use the CDF to write up $\mathbb{P}(x < c)$.

Use the mean to write up $\mathbb{E}(x < c)$.

Step 2: The buyer offers a price p . Write up the seller's strategy (best response).

Step 3: Write out the buyer's problem.

Step 4: Take the first-order and second-order condition wrt. p .

Step 5: Maximize buyer's utility for $k < 2$.

Step 6: **Maximize buyer's utility for $k > 2$.**

1. Standard results for $x \sim U(a, b)$:

$$\text{CDF: } F(x) = \frac{x-a}{b-a} \Rightarrow \mathbb{P}(x < c) = \frac{c-a}{b-a} \quad (\dagger)$$

$$\text{Mean: } \mu = \frac{a+b}{2} \Rightarrow \mathbb{E}(x < c) = \frac{a+c}{2} \quad (\ddagger)$$

$$2. S_s(p, v_s) = \begin{cases} \text{Sell} & \text{if } p \geq v_s \\ \text{Don't} & \text{if } p < v_s \end{cases}$$

$$3. \max_p u_b(p) = \max_p p^2 \left(\frac{k}{2} - 1 \right)$$

$$4. \text{FOC: } p \frac{k}{2} = p$$

$$\text{SOC: } k - 2 \begin{cases} < 0, k \in (1, 2) & \Rightarrow \text{concave} \\ = 0, k = 2 & \Rightarrow \text{flat} \\ > 0, k > 2 & \Rightarrow \text{convex} \end{cases}$$

$$5. k \in (1, 2): \text{FOC, SOC} \Rightarrow p^* = 0$$

PS11, Ex. 2 (A): Asymmetric/incomplete information (PBE)

Exercise 4.11 in Gibbons (p. 250). Difficult. A buyer and a seller have valuations v_b and v_s . It is common knowledge that there are gains from trade (i.e., that $v_b > v_s$), but the size of the gains is private information, as follows: the seller's valuation is uniformly distributed on $[0,1]$; the buyer's valuation $v_b = kv_s$, where $k > 1$ is common knowledge; the seller knows v_s (and hence v_b) but the buyer does not know v_b (and hence v_s). Suppose the buyer makes a single offer, p , which the seller either accepts or rejects. What is the perfect Bayesian equilibrium when $k < 2$? When $k > 2$? (See Samuelson 1984.)

Step 1: Use the CDF to write up $\mathbb{P}(x < c)$.

Use the mean to write up $\mathbb{E}(x < c)$.

Step 2: The buyer offers a price p . Write up the seller's strategy (best response).

Step 3: Write out the buyer's problem.

Step 4: Take the FOC and SOC wrt. p .

Step 5: Maximize buyer's utility for $k < 2$.

Step 6: Maximize buyer's utility for $k > 2$.

Step 7: **Looking at the seller's strategy, will trade occur when $k > 2$?**

What about $k \in (1, 2)$? Have we seen something similar before?

1. Standard results for $x \sim U(a, b)$:

$$\text{CDF: } F(x) = \frac{x-a}{b-a} \Rightarrow \mathbb{P}(x < c) = \frac{c-a}{b-a} \quad (\dagger)$$

$$\text{Mean: } \mu = \frac{a+b}{2} \Rightarrow \mathbb{E}(x < c) = \frac{a+c}{2} \quad (\ddagger)$$

$$2. S_s(p, v_s) = \begin{cases} \text{Sell} & \text{if } p \geq v_s \\ \text{Don't} & \text{if } p < v_s \end{cases}$$

$$3. \max_p u_b(p) = \max_p p^2 \left(\frac{k}{2} - 1 \right)$$

$$4. \text{FOC: } p \frac{k}{2} = p$$

$$\text{SOC: } k - 2 \begin{cases} < 0, k \in (1, 2) & \Rightarrow \text{concave} \\ = 0, k = 2 & \Rightarrow \text{flat} \\ > 0, k > 2 & \Rightarrow \text{convex} \end{cases}$$

$$5. k \in (1, 2): \text{FOC, SOC} \Rightarrow p^* = 0$$

$$6. k > 2: \max u_b: p \rightarrow \infty \Rightarrow p^{**} = 1$$

PS11, Ex. 2 (A): Asymmetric/incomplete information (PBE)

Exercise 4.11 in Gibbons (p. 250). Difficult. A buyer and a seller have valuations v_b and v_s . It is common knowledge that there are gains from trade (i.e., that $v_b > v_s$), but the size of the gains is private information, as follows: the seller's valuation is uniformly distributed on $[0,1]$; the buyer's valuation $v_b = kv_s$, where $k > 1$ is common knowledge; the seller knows v_s (and hence v_b) but the buyer does not know v_b (and hence v_s). Suppose the buyer makes a single offer, p , which the seller either accepts or rejects. What is the perfect Bayesian equilibrium when $k < 2$? When $k > 2$? (See Samuelson 1984.)

Step 1: Use the CDF to write up $\mathbb{P}(x < c)$.

Use the mean to write up $\mathbb{E}(x < c)$.

Step 2: The buyer offers a price p . Write up the seller's strategy (best response).

Step 3: Write out the buyer's problem.

Step 4: Take the FOC and SOC wrt. p .

Step 5: Maximize buyer's utility for $k < 2$.

Step 6: Maximize buyer's utility for $k > 2$.

Step 7: $k > 2$: As $v_s \in [0, 1]$, seller will always accept the price $p^{**} = 1$.

What about $k \in (1, 2)$? Have we seen something similar before?

1. Standard results for $x \sim U(a, b)$:

$$\text{CDF: } F(x) = \frac{x-a}{b-a} \Rightarrow \mathbb{P}(x < c) = \frac{c-a}{b-a} \quad (\dagger)$$

$$\text{Mean: } \mu = \frac{a+b}{2} \Rightarrow \mathbb{E}(x < c) = \frac{a+c}{2} \quad (\ddagger)$$

$$2. S_s(p, v_s) = \begin{cases} \text{Sell} & \text{if } p \geq v_s \\ \text{Don't} & \text{if } p < v_s \end{cases}$$

$$3. \max_p u_b(p) = \max_p p^2 \left(\frac{k}{2} - 1 \right)$$

$$4. \text{FOC: } p \frac{k}{2} = p$$

$$\text{SOC: } k - 2 \begin{cases} < 0, k \in (1, 2) & \Rightarrow \text{concave} \\ = 0, k = 2 & \Rightarrow \text{flat} \\ > 0, k > 2 & \Rightarrow \text{convex} \end{cases}$$

$$5. k \in (1, 2): \text{FOC, SOC} \Rightarrow p^* = 0$$

$$6. k > 2: \max u_b: p \rightarrow \infty \Rightarrow p^{**} = 1$$

PS11, Ex. 2 (A): Asymmetric/incomplete information (PBE)

Exercise 4.11 in Gibbons (p. 250). Difficult. A buyer and a seller have valuations v_b and v_s . It is common knowledge that there are gains from trade (i.e., that $v_b > v_s$), but the size of the gains is private information, as follows: the seller's valuation is uniformly distributed on $[0,1]$; the buyer's valuation $v_b = kv_s$, where $k > 1$ is common knowledge; the seller knows v_s (and hence v_b) but the buyer does not know v_b (and hence v_s). Suppose the buyer makes a single offer, p , which the seller either accepts or rejects. What is the perfect Bayesian equilibrium when $k < 2$? When $k > 2$? (See Samuelson 1984.)

Step 1: Use the CDF to write up $\mathbb{P}(x < c)$.

Use the mean to write up $\mathbb{E}(x < c)$.

Step 2: The buyer offers a price p . Write up the seller's strategy (best response).

Step 3: Write out the buyer's problem.

Step 4: Take the FOC and SOC wrt. p .

Step 5: Maximize buyer's utility for $k < 2$.

Step 6: Maximize buyer's utility for $k > 2$.

Step 7: $k > 2$: As $v_s \in [0, 1]$, seller will always accept the price $p^{**} = 1$.
 $k \in (1, 2)$: Seller will not accept if $v_s > 0$, though trade would benefit both under perfect information.
 Similar to Akerlof's 'Lemons'.

1. Standard results for $x \sim U(a, b)$:

$$\text{CDF: } F(x) = \frac{x-a}{b-a} \Rightarrow \mathbb{P}(x < c) = \frac{c-a}{b-a} \quad (\dagger)$$

$$\text{Mean: } \mu = \frac{a+b}{2} \Rightarrow \mathbb{E}(x < c) = \frac{a+c}{2} \quad (\ddagger)$$

$$2. S_s(p, v_s) = \begin{cases} \text{Sell} & \text{if } p \geq v_s \\ \text{Don't} & \text{if } p < v_s \end{cases}$$

$$3. \max_p u_b(p) = \max_p p^2 \left(\frac{k}{2} - 1 \right)$$

$$4. \text{FOC: } p \frac{k}{2} = p$$

$$\text{SOC: } k - 2 \begin{cases} < 0, k \in (1, 2) & \Rightarrow \text{concave} \\ = 0, k = 2 & \Rightarrow \text{flat} \\ > 0, k > 2 & \Rightarrow \text{convex} \end{cases}$$

5. $k \in (1, 2)$: FOC, SOC $\Rightarrow p^* = 0$

6. $k > 2$: $\max u_b: p \rightarrow \infty \Rightarrow p^{**} = 1$

Signaling games in general

PS11: Signaling games in general

Players:

- 2 players: Sender (S) and receiver (R). E.g. firm and consumer, or employer and employee (Spence).

Timing:

- Nature chooses the sender's type from $T = \{t_1, \dots\}$.
- S: The sender realizes her type and sends a signal from $M = \{m_1, \dots\}$, typically either L (left) or R (right).
- R: The receiver observes m (but not the type t !) and forms his beliefs:

$$\mu(t_1|L) = p \text{ and } \mu(t_1|R) = q$$

Consequently, for S having two possible types:

$$\mu(t_2|L) = 1 - p \text{ and } \mu(t_2|R) = 1 - q$$

- R: The receiver chooses an action from $A = \{a_1, \dots\}$, e.g. *up* or *down*.
- Payoffs are realized.

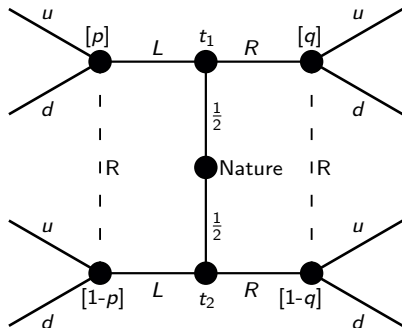

PS11: Signaling games in general

Players:

- 2 players: Sender (S) and receiver (R). E.g. firm and consumer, or employer and employee (Spence).

Timing:

- Nature chooses the sender's type from $T = \{t_1, \dots\}$.
- S: The sender realizes her type and sends a signal from $M = \{m_1, \dots\}$, typically either L (left) or R (right).
- R: The receiver observes m (but not the type t !) and forms his beliefs:
 $p = \mu(t_1|L)$ and $q = \mu(t_1|R)$
Consequently, for S having two possible types:
 $1 - p = \mu(t_2|L)$ and $1 - q = \mu(t_2|R)$
- R: The receiver chooses an action from $A = \{a_1, \dots\}$, e.g. up or $down$.
- Payoffs are realized.

Four possible equilibria for two types:

- Pooling on L or pooling on R .
- Separating: t_1 plays L and t_2 plays R or the other way around.

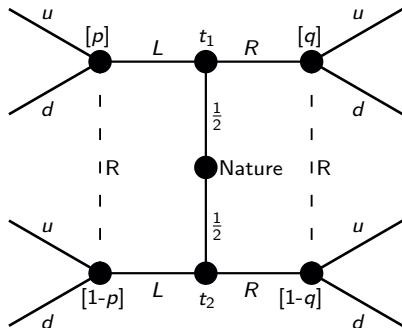

PS11: Signaling games in general

Players:

- 2 players: Sender (S) and receiver (R). E.g. firm and consumer, or employer and employee (Spence).

Timing:

- Nature chooses the sender's type from $T = \{t_1, \dots\}$.
- S: The sender realizes her type and sends a signal from $M = \{m_1, \dots\}$, typically either L (left) or R (right).
- R: The receiver observes m (but not the type t !) and forms his beliefs:

$$p = \mu(t_1|L) \text{ and } q = \mu(t_1|R)$$

Consequently, for S having two possible types:

$$1 - p = \mu(t_2|L) \text{ and } 1 - q = \mu(t_2|R)$$

- R: The receiver chooses an action from $A = \{a_1, \dots\}$, e.g. up or $down$.
- Payoffs are realized.

Four possible equilibria for two types:

- Pooling on L or pooling on R .
- Separating: t_1 plays L and t_2 plays R or the other way around.

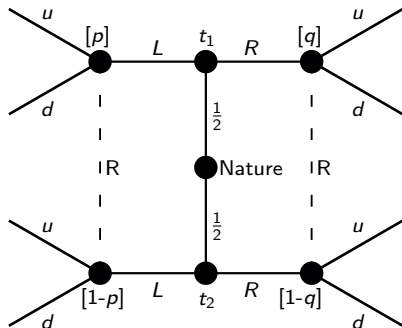

Cookbook: For each possible equilibrium go over signaling requirements 3 and 2:

- SR3: R: Find the beliefs p, q given S 's eq. strategy. (Only consider beliefs that are consistent with S 's eq. strategy.)
- SR2R: R: Given beliefs, find $a(m_j|\mu(t_1|m_j))$.
- SR2S: S: Does t_1 or t_2 want to deviate?
- PBE: No deviation \rightarrow PBE. Pooling on L : Find off-eq. $a(R|q) \rightarrow$ possibly two different PBE for different q .

**PS11, Ex. 3: Signaling game
(pooling and separating PBE)**

PS11, Ex. 3: Signaling game (pooling and separating PBE)

Consider the signaling game in Figure 1.

- Suppose there is a pooling PBE where the Sender sends message L regardless of his type. What are the beliefs in this equilibrium?
- Consider a possible separating PBE where t_1 sends message R , t_2 sends message L , and where the receiver chooses u if and only if he receives message L . Can you write down payoffs for this game such that nobody has an incentive to deviate?

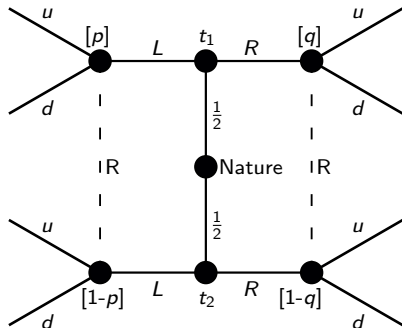

PS11, Ex. 3.a: Signaling game (pooling and separating PBE)

- (a) Suppose there is a pooling PBE where the Sender sends message L regardless of his type. What are the beliefs in this equilibrium?

SR3: **R**: Find the beliefs of R given S's equilibrium strategy. (In equilibrium, we only consider beliefs of R that are consistent with S's equilibrium strategy.)

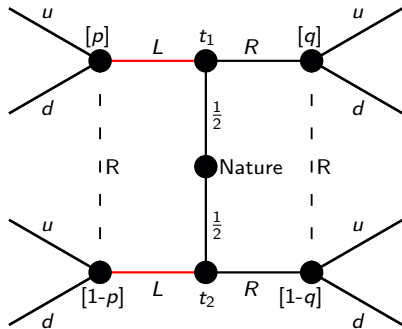

PS11, Ex. 3.a: Signaling game (pooling and separating PBE)

(a) Suppose there is a pooling PBE where the Sender sends message L regardless of his type. What are the beliefs in this equilibrium?

SR3: R: Find the beliefs of R given S's equilibrium strategy. (In equilibrium, we only consider beliefs of R that are consistent with S's eq. strategy.):

$$\mu(t_1|L) = \mu(t_2|L) = \frac{1}{2}$$

$$\Rightarrow p = 1 - p = \frac{1}{2}$$

$$q \in [0; 1]$$

I.e. in a pooling perfect Bayesian equilibrium where S always sends the message L , the receiver R believes that S can be type t_1 or t_2 with equal probability as the signal does not reveal anything.

As the message R is not a part of S's equilibrium strategy, the receiver R has no beliefs about q other than $q \in [0, 1]$ in the case where S would unexpectedly send the message R instead.

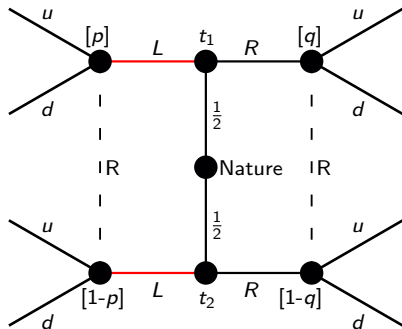

PS11, Ex. 3.b: Signaling game (pooling and separating PBE)

- (b) Consider a possible separating PBE where t_1 sends message R , t_2 sends message L , and where the receiver chooses u if and only if he receives message L . Can you write down payoffs for this game such that nobody has an incentive to deviate?

SR3:

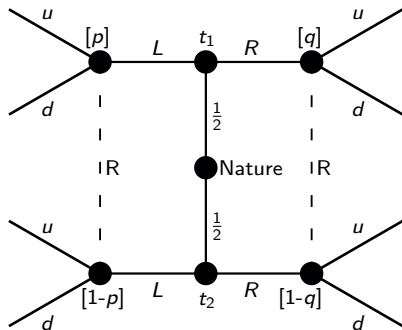

PS11, Ex. 3.b: Signaling game (pooling and separating PBE)

- (b) Consider a possible separating PBE where t_1 sends message R , t_2 sends message L , and where the receiver chooses u if and only if he receives message L . Can you write down payoffs for this game such that nobody has an incentive to deviate?

SR3: **R:** Find the beliefs of R given S's equilibrium strategy. (In equilibrium, we only consider beliefs of R that are consistent with S's equilibrium strategy.)

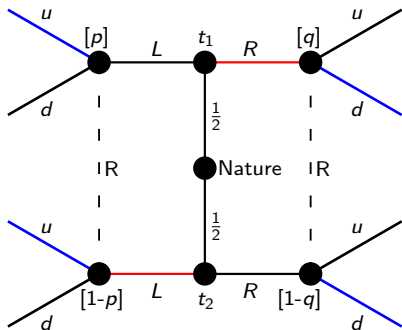

PS11, Ex. 3.b: Signaling game (pooling and separating PBE)

(b) Consider a possible separating PBE where t_1 sends message R , t_2 sends message L , and where the receiver chooses u if and only if he receives message L . Can you write down payoffs for this game such that nobody has an incentive to deviate?

SR3: R: Find the beliefs of R given S's equilibrium strategy. (In equilibrium, we only consider beliefs of R that are consistent with S's eq. strategy.)

SR2R:

SR2S:

PBE:

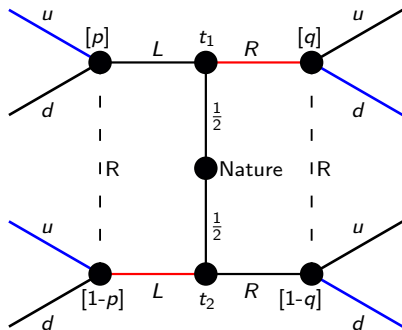

SR3: In the separating PBE, R has beliefs:

$$\mu(t_1|L) = p^* = 0$$

$$\mu(t_1|R) = q^* = 1$$

PS11, Ex. 3.b: Signaling game (pooling and separating PBE)

(b) Consider a possible separating PBE where t_1 sends message R , t_2 sends message L , and where the receiver chooses u if and only if he receives message L . Can you write down payoffs for this game such that nobody has an incentive to deviate?

SR3: R: Find the beliefs of R given S's equilibrium strategy. (In equilibrium, we only consider beliefs of R that are consistent with S's eq. strategy.)

SR2R: R: Find R's optimal strategy given beliefs about S's strategy.

SR2S: S: Check whether S wants to deviate.

PBE: **Write up the conditions such that SR2R and SR2S hold (no incentive to deviate) for the following PBE:**

$$\left\{ \underbrace{(R, L)}_{m(t_1)}, \underbrace{(u, d)}_{a(L)}, \underbrace{(u, d)}_{a(R)}, \underbrace{p=0, q=1}_{\mu(t_1|L), \mu(t_1|R)} \right\}$$

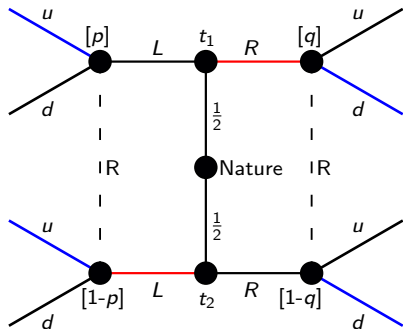

SR3: In the separating PBE, R has beliefs:

$$\mu(t_1|L) = p^* = 0$$

$$\mu(t_1|R) = q^* = 1$$

PS11, Ex. 3.b: Signaling game (pooling and separating PBE)

(b) Consider a possible separating PBE where t_1 sends message R , t_2 sends message L , and where the receiver chooses u if and only if he receives message L . Can you write down payoffs for this game such that nobody has an incentive to deviate?

SR3: R: Find the beliefs of R given S's equilibrium strategy. (In equilibrium, we only consider beliefs of R that are consistent with S's eq. strategy.)

SR2R: R: Find R's optimal strategy given beliefs about S's strategy.

SR2S: S: Check whether S wants to deviate.

PBE: **Write up the conditions such that SR2R and SR2S hold (no incentive to deviate) for the following PBE:**

$$\left\{ \underbrace{(R, L)}_{m(t_1)}, \underbrace{(u, d)}_{a(L)}, \underbrace{(u, d)}_{a(R)}, \underbrace{p=0, q=1}_{\mu(t_1|L), \mu(t_1|R)} \right\}$$

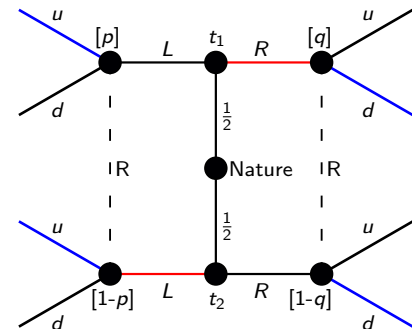

SR3: In the separating PBE, R has beliefs:

$$\mu(t_1|L) = p^* = 0$$

$$\mu(t_1|R) = q^* = 1$$

$$\text{SR2R: } \mathbb{E}[u_R(L, u|p=0)] \geq \mathbb{E}[u_R(L, d|p=0)]$$

$$\mathbb{E}[u_R(R, d|q=1)] \geq \mathbb{E}[u_R(R, u|q=1)]$$

PS11, Ex. 3.b: Signaling game (pooling and separating PBE)

(b) Consider a possible separating PBE where t_1 sends message R , t_2 sends message L , and where the receiver chooses u if and only if he receives message L . Can you write down payoffs for this game such that nobody has an incentive to deviate?

SR3: R: Find the beliefs of R given S's equilibrium strategy. (In equilibrium, we only consider beliefs of R that are consistent with S's eq. strategy.)

SR2R: R: Find R's optimal strategy given beliefs about S's strategy.

SR2S: S: Check whether S wants to deviate.

PBE: Write up the conditions such that SR2R and SR2S hold (no incentive to deviate) for the following PBE:

$$\left\{ \underbrace{(R, L)}_{m(t_1)}, \underbrace{(u, d)}_{a(L)}, \underbrace{(u, d)}_{a(R)}, \underbrace{p=0, q=1}_{\mu(t_1|L), \mu(t_1|R)} \right\}$$

→ **Construct payoffs that live up to these conditions.**

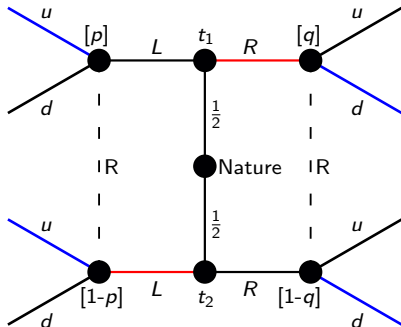

SR3: In the separating PBE, R has beliefs:
 $\mu(t_1|L) = p^* = 0$

$$\mu(t_1|R) = q^* = 1$$

SR2R: $\mathbb{E}[u_R(L, u|p=0)] \geq \mathbb{E}[u_R(L, d|p=0)]$
 $\mathbb{E}[u_R(R, d|q=1)] \geq \mathbb{E}[u_R(R, u|q=1)]$

SR2S: $u_S(R, d|t_1) \geq u_S(L, u|t_1)$
 $u_S(L, u|t_2) \geq u_S(R, d|t_2)$

PS11, Ex. 3.b: Signaling game (pooling and separating PBE)

(b) Consider a possible separating PBE where t_1 sends message R , t_2 sends message L , and where the receiver chooses u if and only if he receives message L . Can you write down payoffs for this game such that nobody has an incentive to deviate?

SR3: R: Find the beliefs of R given S's equilibrium strategy. (In equilibrium, we only consider beliefs of R that are consistent with S's eq. strategy.)

SR2R: R: Find R's optimal strategy given beliefs about S's strategy.

SR2S: S: Check whether S wants to deviate.

PBE: Write up the conditions such that SR2R and SR2S hold (no incentive to deviate) for the following PBE:

$$\left\{ \underbrace{(R, L)}_{m(t_1)}, \underbrace{(u, d)}_{a(L)}, \underbrace{(u, d)}_{a(R)}, p=0, q=1 \right\}$$

$$\underbrace{\mu(t_1|L)}_{\mu(t_1|L)}, \underbrace{\mu(t_1|R)}_{\mu(t_1|R)}$$

→ Construct payoffs that live up to these conditions. (first example)

i: *Simplest possible example.*

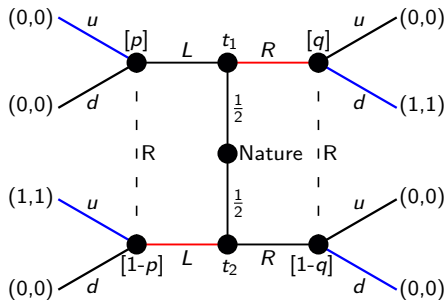

SR3: In the separating PBE, R has beliefs:
 $\mu(t_1|L) = p^* = 0$
 $\mu(t_1|R) = q^* = 1$

SR2R: $\mathbb{E}[u_R(L, u|p=0)] \geq \mathbb{E}[u_R(L, d|p=0)]$
 $\mathbb{E}[u_R(R, d|q=1)] \geq \mathbb{E}[u_R(R, u|q=1)]$

SR2S: $u_S(R, d|t_1) \geq u_S(L, u|t_1)$
 $u_S(L, u|t_2) \geq u_S(R, d|t_2)$

PS11, Ex. 3.b: Signaling game (pooling and separating PBE)

(b) Consider a possible separating PBE where t_1 sends message R , t_2 sends message L , and where the receiver chooses u if and only if he receives message L . Can you write down payoffs for this game such that nobody has an incentive to deviate?

SR3: R: Find the beliefs of R given S's equilibrium strategy. (In equilibrium, we only consider beliefs of R that are consistent with S's eq. strategy.)

SR2R: R: Find R's optimal strategy given beliefs about S's strategy.

SR2S: S: Check whether S wants to deviate.

PBE: Write up the conditions such that SR2R and SR2S hold (no incentive to deviate) for the following PBE:

$\{(\underbrace{R}_{m(t_1)}, \underbrace{L}_{m(t_2)}), (\underbrace{u}_{a(L)}, \underbrace{d}_{a(R)}), \underbrace{p=0}_{\mu(t_1|L)}, \underbrace{q=1}_{\mu(t_1|R)}\}$ SR3: In the separating PBE, R has beliefs:

$$\mu(t_1|L) = p^* = 0$$

$$\mu(t_1|R) = q^* = 1$$

→ Construct payoffs that live up to these conditions. (second example)

i: Simplest possible example.

ii: **Does the PBE still hold for this example?**

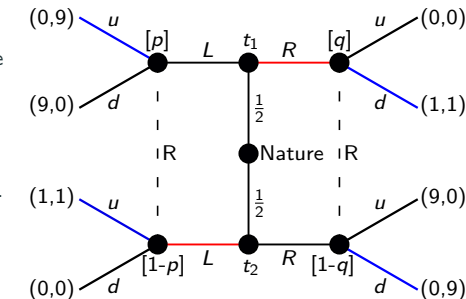

SR2R: $\mathbb{E}[u_R(L, u|p=0)] \geq \mathbb{E}[u_R(L, d|p=0)]$
 $\mathbb{E}[u_R(R, d|q=1)] \geq \mathbb{E}[u_R(R, u|q=1)]$

SR2S: $u_5(R, d|t_1) \geq u_5(L, u|t_1)$
 $u_5(L, u|t_2) \geq u_5(R, d|t_2)$

PS11, Ex. 3.b: Signaling game (pooling and separating PBE)

(b) Consider a possible separating PBE where t_1 sends message R , t_2 sends message L , and where the receiver chooses u if and only if he receives message L . Can you write down payoffs for this game such that nobody has an incentive to deviate?

SR3: R: Find the beliefs of R given S's equilibrium strategy. (In equilibrium, we only consider beliefs of R that are consistent with S's eq. strategy.)

SR2R: R: Find R's optimal strategy given beliefs about S's strategy.

SR2S: S: Check whether S wants to deviate.

PBE: Write up the conditions such that SR2R and SR2S hold (no incentive to deviate) for the following PBE:

$$\left\{ \underbrace{(R, L)}_{m(t_1)}, \underbrace{(L, R)}_{m(t_2)}, \underbrace{(u, d)}_{a(L)}, \underbrace{(d, u)}_{a(R)}, \underbrace{p=0, q=1}_{\mu(t_1|L), \mu(t_1|R)} \right\}$$

→ Construct payoffs that live up to these conditions. (second example)

i: Simplest possible example.

ii: Yes, all conditions still hold.

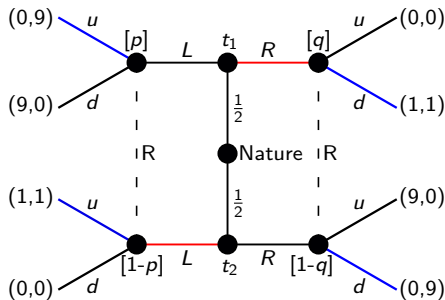

SR3: In the separating PBE, R has beliefs:
 $\mu(t_1|L) = p^* = 0$
 $\mu(t_1|R) = q^* = 1$

SR2R: $\mathbb{E}[u_R(L, u|p=0)] \geq \mathbb{E}[u_R(L, d|p=0)]$
 $\mathbb{E}[u_R(R, d|q=1)] \geq \mathbb{E}[u_R(R, u|q=1)]$

SR2S: $u_5(R, d|t_1) \geq u_5(L, u|t_1)$
 $u_5(L, u|t_2) \geq u_5(R, d|t_2)$

PS11, Ex. 3.b: Signaling game (pooling and separating PBE)

(b) Consider a possible separating PBE where t_1 sends message R , t_2 sends message L , and where the receiver chooses u if and only if he receives message L . Can you write down payoffs for this game such that nobody has an incentive to deviate?

SR3: R: Find the beliefs of R given S's equilibrium strategy. (In equilibrium, we only consider beliefs of R that are consistent with S's eq. strategy.)

SR2R: R: Find R's optimal strategy given beliefs about S's strategy.

SR2S: S: Check whether S wants to deviate.

PBE: Write up the conditions such that SR2R and SR2S hold (no incentive to deviate) for the following PBE:

$\{(\underbrace{R}_{m(t_1)}, \underbrace{L}_{m(t_2)}), (\underbrace{u}_{a(L)}, \underbrace{d}_{a(R)}), \underbrace{p=0}_{\mu(t_1|L)}, \underbrace{q=1}_{\mu(t_1|R)}\}$

→ Construct payoffs that live up to these conditions. (third example)

i: Simplest possible example.

ii: Yes, all conditions still hold.

iii: **What about zero payoffs all over?**

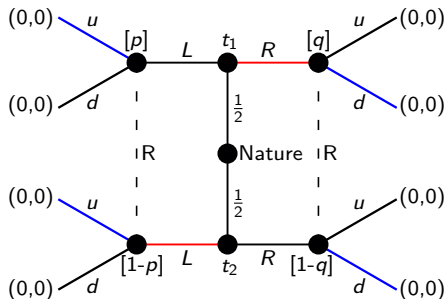

SR3: In the separating PBE, R has beliefs:
 $\mu(t_1|L) = p^* = 0$
 $\mu(t_1|R) = q^* = 1$

SR2R: $\mathbb{E}[u_R(L, u|p=0)] \geq \mathbb{E}[u_R(L, d|p=0)]$
 $\mathbb{E}[u_R(R, d|q=1)] \geq \mathbb{E}[u_R(R, u|q=1)]$

SR2S: $u_S(R, d|t_1) \geq u_S(L, u|t_1)$
 $u_S(L, u|t_2) \geq u_S(R, d|t_2)$

PS11, Ex. 3.b: Signaling game (pooling and separating PBE)

(b) Consider a possible separating PBE where t_1 sends message R , t_2 sends message L , and where the receiver chooses u if and only if he receives message L . Can you write down payoffs for this game such that nobody has an incentive to deviate?

SR3: R: Find the beliefs of R given S's equilibrium strategy. (In equilibrium, we only consider beliefs of R that are consistent with S's eq. strategy.)

SR2R: R: Find R's optimal strategy given beliefs about S's strategy.

SR2S: S: Check whether S wants to deviate.

PBE: Write up the conditions such that SR2R and SR2S hold (no incentive to deviate) for the following PBE:

$\{(\underbrace{R}_{m(t_1)}, \underbrace{L}_{m(t_2)}), (\underbrace{u}_{a(L)}, \underbrace{d}_{a(R)}), \underbrace{p=0}_{\mu(t_1|L)}, \underbrace{q=1}_{\mu(t_1|R)}\}$

→ Construct payoffs that live up to these conditions. (third example)

i: Simplest possible example.

ii: Yes, all conditions still hold.

iii: *All conditions hold with equality.*

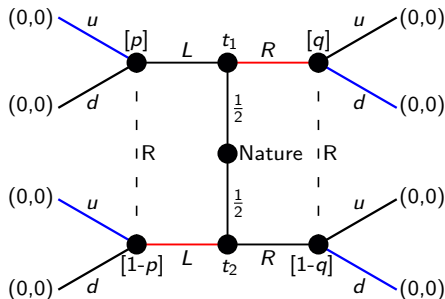

SR3: In the separating PBE, R has beliefs:
 $\mu(t_1|L) = p^* = 0$
 $\mu(t_1|R) = q^* = 1$

SR2R: $\mathbb{E}[u_R(L, u|p=0)] \geq \mathbb{E}[u_R(L, d|p=0)]$
 $\mathbb{E}[u_R(R, d|q=1)] \geq \mathbb{E}[u_R(R, u|q=1)]$

SR2S: $u_5(R, d|t_1) \geq u_5(L, u|t_1)$
 $u_5(L, u|t_2) \geq u_5(R, d|t_2)$

**PS11, Ex. 4: Signaling games
(pooling and separating PBE)**

PS11, Ex. 4.a: Signaling games (pooling and separating PBE)

Exercise 4.4.a in Gibbons (p. 248). Describe all the pure-strategy pooling and separating perfect Bayesian equilibria in the following signaling game.

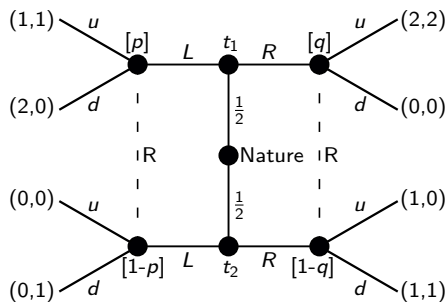

PS11, Ex. 4.a: Signaling games (pooling and separating PBE)

Exercise 4.4.a in Gibbons (p. 248). Describe all the pure-strategy pooling and separating perfect Bayesian equilibria in the following signaling game.

Step 1: Write up S's possible strategies.

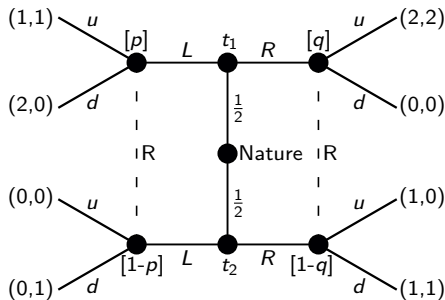

PS11, Ex. 4.a: Signaling games (pooling and separating PBE)

Exercise 4.4.a in Gibbons (p. 248). Describe all the pure-strategy pooling and separating perfect Bayesian equilibria in the following signaling game.

Step 1: Write up S's possible strategies.

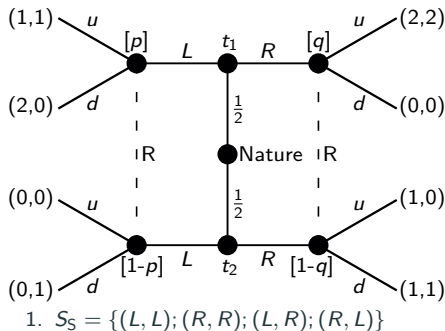

PS11, Ex. 4.a: Signaling games (pooling and separating PBE)

Exercise 4.4.a in Gibbons (p. 248). Describe all the pure-strategy pooling and separating perfect Bayesian equilibria in the following signaling game.

Step 1: Write up S's possible strategies.

Step 2: **For the pooling strategy (L,L) , go over SR3, SR2R, and SR2S.**

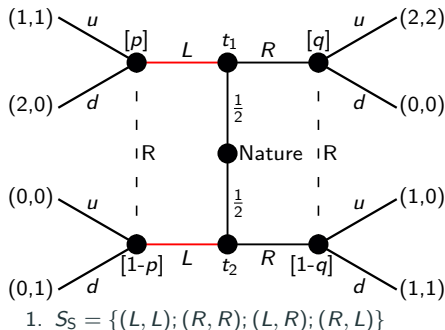

PS11, Ex. 4.a: Signaling games (pooling and separating PBE)

Exercise 4.4.a in Gibbons (p. 248). Describe all the pure-strategy pooling and separating perfect Bayesian equilibria in the following signaling game.

Step 1: Write up S's possible strategies.

Step 2: For the pooling strategy (L,L) , go over SR3, SR2R, and SR2S:

SR3: R: Beliefs given S's eq. strategy:

$$\mu(t_1|L) = p = \frac{1}{2} \text{ and } \mu(t_1|R) = q \in [0, 1]$$

SR2R: R: Indifferent between u and d :

$$\mathbb{E}[u_R(L, u|p)] = \mathbb{E}[u_R(L, d|p)]$$

$$1p + 0[1-p] = 0p + 1[1-p]$$

$$\frac{1}{2} = \frac{1}{2}$$

SR2S: S: t_2 wants to deviate as $L|t_2$ is strictly dominated by $R|t_2$.

PBE: Not a PBE as t_2 would deviate.

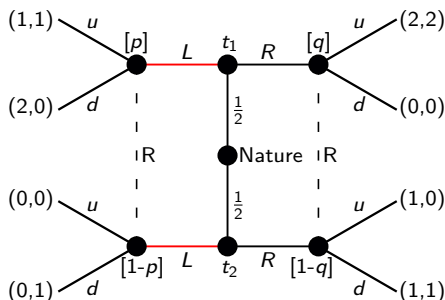

- $S_S = \{(L, L); (R, R); (L, R); (R, L)\}$
- No PBE that includes (L, L) .

PS11, Ex. 4.a: Signaling games (pooling and separating PBE)

Exercise 4.4.a in Gibbons (p. 248). Describe all the pure-strategy pooling and separating perfect Bayesian equilibria in the following signaling game.

Step 1: Write up S's possible strategies.

Step 2: For the pooling strategy (L,L) , go over SR3, SR2R, and SR2S.

Step 3: **For the pooling strategy (R,R) , go over SR3, SR2R, and SR2S.**

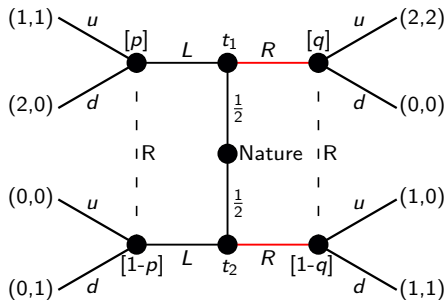

- $S_S = \{(L, L); (R, R); (L, R); (R, L)\}$
- No PBE that includes (L, L) .

PS11, Ex. 4.a: Signaling games (pooling and separating PBE)

Exercise 4.4.a in Gibbons (p. 248). Describe all the pure-strategy pooling and separating perfect Bayesian equilibria in the following signaling game.

Step 1: Write up S's possible strategies.

Step 2: For the pooling strategy (L,L) , go over SR3, SR2R, and SR2S.

Step 3: For the pooling strategy (R,R) , go over SR3, SR2R, and SR2S:

SR3: R: Beliefs given S's eq. strategy:

$$\mu(t_1|L) = p \in [0, 1] \text{ and } \mu(t_1|R) = q = \frac{1}{2}$$

SR2R: R: Best response is to play u as

$$\mathbb{E}[u_R(R, u|q=\frac{1}{2})] = 2\frac{1}{2} + 0\frac{1}{2} = 1$$

$$\mathbb{E}[u_R(R, d|q=\frac{1}{2})] = 0\frac{1}{2} + 1\frac{1}{2} = \frac{1}{2}$$

SR2S: t_1 will not deviate even if $a(L) = d$:

$$u_S(R, u|t_1) = 2 \geq 2 = \max u_S(L, a(L)|t_1)$$

t_2 will not deviate as $R|t_2$ strictly dominates $L|t_2$.

PBE: Find the off-equilibrium beliefs p to identify $a(L|p)$ (possibly 2 for different p .)

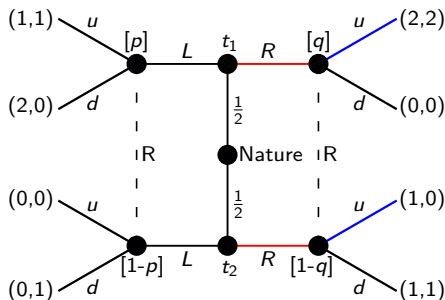

1. $S_S = \{(L, L); (R, R); (L, R); (R, L)\}$
2. No PBE that includes (L, L) .
- 3.

PS11, Ex. 4.a: Signaling games (pooling and separating PBE)

Exercise 4.4.a in Gibbons (p. 248). Describe all the pure-strategy pooling and separating perfect Bayesian equilibria in the following signaling game.

Step 1: Write up S's possible strategies.

Step 2: For the pooling strategy (L,L) , go over SR3, SR2R, and SR2S.

Step 3: For the pooling strategy (R,R) , go over SR3, SR2R, and SR2S:

SR3: R: Beliefs given S's eq. strategy:

$$\mu(t_1|L) = p \in [0, 1] \text{ and } \mu(t_1|R) = q = \frac{1}{2}$$

SR2R: R: Best response is to play u as

$$\mathbb{E}[u_R(R, u|q=\frac{1}{2})] = 2\frac{1}{2} + 0\frac{1}{2} = 1$$

$$\mathbb{E}[u_R(R, d|q=\frac{1}{2})] = 0\frac{1}{2} + 1\frac{1}{2} = \frac{1}{2}$$

SR2S: t_1 will not deviate even if $a(L) = d$:

$$u_S(R, u|t_1) = 2 \geq 2 = \max u_S(L, a(L)|t_1)$$

t_2 will not deviate as $R|t_2$ strictly dominates $L|t_2$.

PBE: Find the off-equilibrium beliefs p to identify (two different) $a(L|p)$:

$$\mathbb{E}[u_R(L, u|p) \geq \mathbb{E}[u_R(L, d|p)$$

$$1p + 0[1 - p] \geq 0p + 1[1 - p]$$

$$p \geq 1/2$$

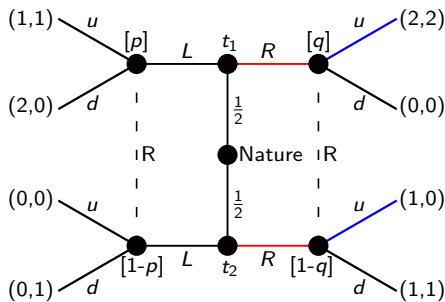

1. $S_S = \{(L, L); (R, R); (L, R); (R, L)\}$
2. No PBE that includes (L, L) .
3. **Write up all PBE including (R, R) .**

PS11, Ex. 4.a: Signaling games (pooling and separating PBE)

Exercise 4.4.a in Gibbons (p. 248). Describe all the pure-strategy pooling and separating perfect Bayesian equilibria in the following signaling game.

Step 1: Write up S's possible strategies.

Step 2: For the pooling strategy (L,L) , go over SR3, SR2R, and SR2S.

Step 3: For the pooling strategy (R,R) , go over SR3, SR2R, and SR2S:

SR3: R: Beliefs given S's eq. strategy:

$$\mu(t_1|L) = p \in [0, 1] \text{ and } \mu(t_1|R) = q = \frac{1}{2}$$

SR2R: R: Best response is to play u as

$$\mathbb{E}[u_R(R, u|q=\frac{1}{2})] = 2\frac{1}{2} + 0\frac{1}{2} = 1$$

$$\mathbb{E}[u_R(R, d|q=\frac{1}{2})] = 0\frac{1}{2} + 1\frac{1}{2} = \frac{1}{2}$$

SR2S: t_1 will not deviate even if $a(L) = d$:

$$u_S(R, u|t_1) = 2 \geq 2 = \max u_S(L, a(L)|t_1)$$

t_2 will not deviate as $R|t_2$ strictly dominates $L|t_2$.

PBE: Find the off-equilibrium beliefs p to identify (two different) $a(L|p)$:

$$\mathbb{E}[u_R(L, u|p)] \geq \mathbb{E}[u_R(L, d|p)]$$

$$1p + 0[1 - p] \geq 0p + 1[1 - p]$$

$$p \geq 1/2$$

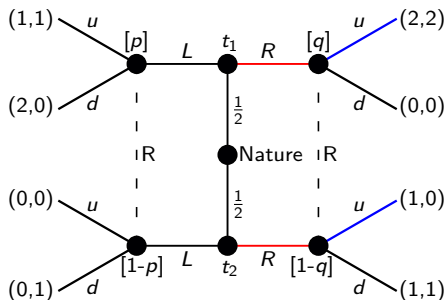

$$1. S_S = \{(L, L); (R, R); (L, R); (R, L)\}$$

2. No PBE that includes (L, L) .

$$3. \left\{ \begin{array}{l} (R, R), (u, u), p \geq \frac{1}{2}, q = \frac{1}{2} \\ (R, R), (d, u), p \leq \frac{1}{2}, q = \frac{1}{2} \end{array} \right\}$$

PS11, Ex. 4.a: Signaling games (pooling and separating PBE)

Exercise 4.4.a in Gibbons (p. 248). Describe all the pure-strategy pooling and separating perfect Bayesian equilibria in the following signaling game.

Step 1: Write up S's possible strategies.

Step 2: For the pooling strategy (L,L) , go over SR3, SR2R, and SR2S.

Step 3: For the pooling strategy (R,R) , go over SR3, SR2R, and SR2S.

Step 4: **For the separating strategy (L,R) , go over SR3, SR2R, and SR2S.**

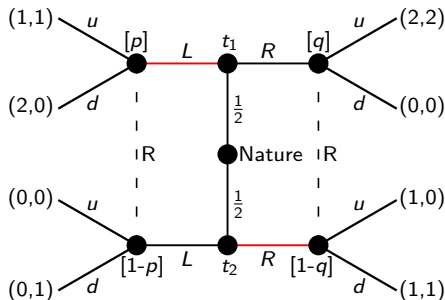

- $S_S = \{(L, L); (R, R); (L, R); (R, L)\}$
- No PBE that includes (L, L) .
- $\left\{ \begin{array}{l} (R, R), (u, u), p \geq \frac{1}{2}, q = \frac{1}{2} \\ (R, R), (d, u), p \leq \frac{1}{2}, q = \frac{1}{2} \end{array} \right\}$

PS11, Ex. 4.a: Signaling games (pooling and separating PBE)

Exercise 4.4.a in Gibbons (p. 248). Describe all the pure-strategy pooling and separating perfect Bayesian equilibria in the following signaling game.

Step 1: Write up S's possible strategies.

Step 2: For the pooling strategy (L,L) , go over SR3, SR2R, and SR2S.

Step 3: For the pooling strategy (R,R) , go over SR3, SR2R, and SR2S.

Step 4: For the separating strategy (L,R) , go over SR3, SR2R, and SR2S:

SR3: R: Beliefs given S's eq. strategy:

$$\mu(t_1|L) = p = 1 \text{ and } \mu(t_1|R) = q = 0$$

SR2R: R: Best response is to play $u|L, d|R$.

SR2S: t_1 will not deviate as

$$u_S(L, u|t_1) = 1 > 0 = u_S(R, d|t_1)$$

t_2 will not deviate as

$$u_S(R, d|t_2) = 1 > 0 = u_S(L, u|t_2)$$

PBE: No deviation, thus, it's a PBE.

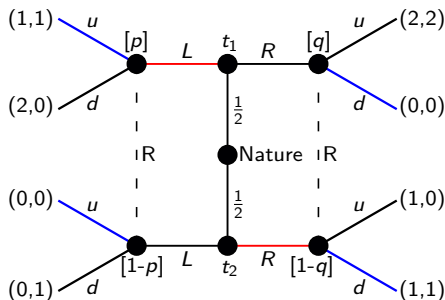

$$1. S_S = \{(L, L); (R, R); (L, R); (R, L)\}$$

2. No PBE that includes (L, L) .

$$3. \left\{ \begin{array}{l} (R, R), (u, u), p \geq \frac{1}{2}, q = \frac{1}{2} \\ (R, R), (d, u), p \leq \frac{1}{2}, q = \frac{1}{2} \end{array} \right\}$$

$$4. \left\{ (L, R), (u, d), p = 1, q = 0 \right\}$$

PS11, Ex. 4.a: Signaling games (pooling and separating PBE)

Exercise 4.4.a in Gibbons (p. 248). Describe all the pure-strategy pooling and separating perfect Bayesian equilibria in the following signaling game.

Step 1: Write up S's possible strategies.

Step 2: For the pooling strategy (L,L) , go over SR3, SR2R, and SR2S.

Step 3: For the pooling strategy (R,R) , go over SR3, SR2R, and SR2S.

Step 4: For the separating strategy (L,R) , go over SR3, SR2R, and SR2S.

Step 5: **For the separating strategy (R,L) , go over SR3, SR2R, and SR2S.**

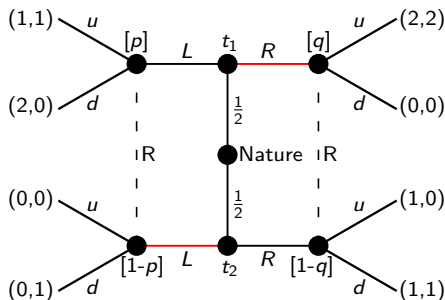

- $S_S = \{(L, L); (R, R); (L, R); (R, L)\}$
- No PBE that includes (L, L) .
- $\left\{ \begin{array}{l} (R, R), (u, u), p \geq \frac{1}{2}, q = \frac{1}{2} \\ (R, R), (d, u), p \leq \frac{1}{2}, q = \frac{1}{2} \end{array} \right\}$
- $\left\{ (L, R), (u, d), p = 1, q = 0 \right\}$

PS11, Ex. 4.a: Signaling games (pooling and separating PBE)

Exercise 4.4.a in Gibbons (p. 248). Describe all the pure-strategy pooling and separating perfect Bayesian equilibria in the following signaling game.

Step 1: Write up S's possible strategies.

Step 2: For the pooling strategy (L,L) , go over SR3, SR2R, and SR2S.

Step 3: For the pooling strategy (R,R) , go over SR3, SR2R, and SR2S.

Step 4: For the separating strategy (L,R) , go over SR3, SR2R, and SR2S.

Step 5: For the separating strategy (R,L) , go over SR3, SR2R, and SR2S:

SR3: R: Beliefs given S's eq. strategy:

$$\mu(t_1|L) = p = 0 \text{ and } \mu(t_1|R) = q = 1$$

SR2R: R: Best response is to play $d|L, u|R$.

SR2S: t_2 wants to deviate as

$$u_S(L, d|t_2) = 0 < 1 = u_S(R, u|t_2)$$

PBE: No PBE as t_2 will want to deviate.

Step 6: **Write up the full set of PBE.**

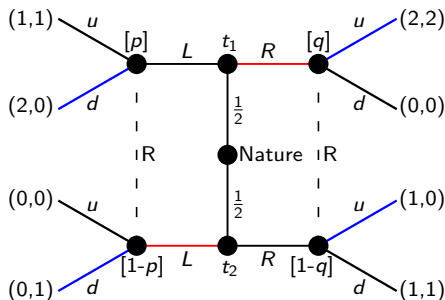

1. $S_S = \{(L, L); (R, R); (L, R); (R, L)\}$

2. No PBE that includes (L, L) .

3. $\left\{ \begin{array}{l} (R, R), (u, u), p \geq \frac{1}{2}, q = \frac{1}{2} \\ (R, R), (d, u), p \leq \frac{1}{2}, q = \frac{1}{2} \end{array} \right\}$

4. $\left\{ (L, R), (u, d), p = 1, q = 0 \right\}$

5. No PBE that includes (R, L) .

PS11, Ex. 4.a: Signaling games (pooling and separating PBE)

Exercise 4.4.a in Gibbons (p. 248). Describe all the pure-strategy pooling and separating perfect Bayesian equilibria in the following signaling game.

Step 1: Write up S's possible strategies.

Step 2: For the pooling strategy (L,L) , go over SR3, SR2R, and SR2S.

Step 3: For the pooling strategy (R,R) , go over SR3, SR2R, and SR2S.

Step 4: For the separating strategy (L,R) , go over SR3, SR2R, and SR2S.

Step 5: For the separating strategy (R,L) , go over SR3, SR2R, and SR2S:

Step 6: Write up the full set of PBE.

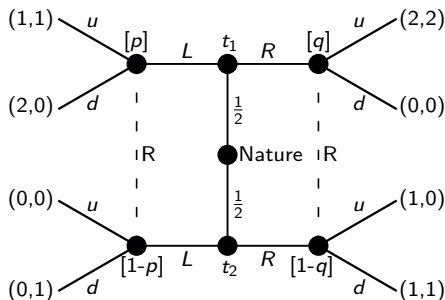

1. $S_S = \{(L, L); (R, R); (L, R); (R, L)\}$

2. No PBE that includes (L, L) .

3. $\left\{ \begin{array}{l} (R, R), (u, u), p \geq \frac{1}{2}, q = \frac{1}{2} \\ (R, R), (d, u), p \leq \frac{1}{2}, q = \frac{1}{2} \end{array} \right\}$

4. $\left\{ (L, R), (u, d), p = 1, q = 0 \right\}$

5. No PBE that includes (R, L) .

6. $\left\{ \begin{array}{l} (R, R), (u, u), p \geq \frac{1}{2}, q = \frac{1}{2} \\ (R, R), (d, u), p \leq \frac{1}{2}, q = \frac{1}{2} \\ (L, R), (u, d), p = 1, q = 0 \end{array} \right\}$

PS11, Ex. 4.b: Signaling games (pooling and separating PBE)

Exercise 4.4.b in Gibbons (p. 248). Describe all the pure-strategy pooling and separating perfect Bayesian equilibria in the following signaling game.

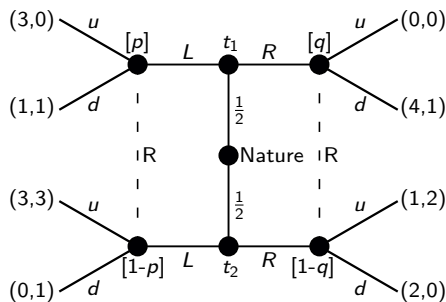

PS11, Ex. 4.b: Signaling games (pooling and separating PBE)

Exercise 4.4.b in Gibbons (p. 248). Describe all the pure-strategy pooling and separating perfect Bayesian equilibria in the following signaling game.

- Consider S 's possible strategies:

$$S_S = \{(L, L); (R, R); (L, R); (R, L)\}$$

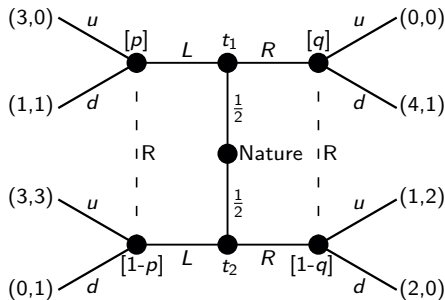

PS11, Ex. 4.b: Signaling games (pooling and separating PBE)

Exercise 4.4.b in Gibbons (p. 248). Describe all the pure-strategy pooling and separating perfect Bayesian equilibria in the following signaling game.

- Consider S 's possible strategies:

$$S_S = \{(L, L); (R, R); (L, R); (R, L)\}$$

Step 1: For the pooling strategy (L, L) , go over SR3, SR2R, and SR2S.

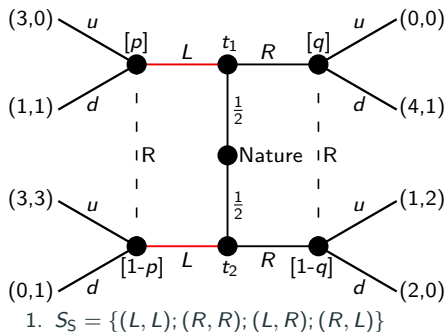

PS11, Ex. 4.b: Signaling games (pooling and separating PBE)

Exercise 4.4.b in Gibbons (p. 248). Describe all the pure-strategy pooling and separating perfect Bayesian equilibria in the following signaling game.

- Consider S's possible strategies:

$$S_S = \{(L, L); (R, R); (L, R); (R, L)\}$$

Step 1: For the pooling strategy (L, L) , go over SR3, SR2R, and SR2S:

SR3: R: Beliefs given S's eq. strategy:

$$\mu(t_1|L) = p = \frac{1}{2} \text{ and } \mu(t_1|R) = q \in [0, 1]$$

SR2R: R: Best response is to play $u|L$ as

$$\mathbb{E}[u_R(L, u|p=\frac{1}{2})] = 0\frac{1}{2} + 3\frac{1}{2} = \frac{3}{2}$$

$$\mathbb{E}[u_R(L, d|p=\frac{1}{2})] = 1\frac{1}{2} + 1\frac{1}{2} = 1$$

SR2S: t_1, t_2 will not deviate if R plays $u|R$.

PBE: **So, now what?**

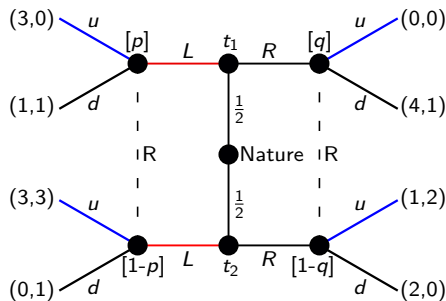

PS11, Ex. 4.b: Signaling games (pooling and separating PBE)

Exercise 4.4.b in Gibbons (p. 248). Describe all the pure-strategy pooling and separating perfect Bayesian equilibria in the following signaling game.

- Consider S's possible strategies:

$$S_S = \{(L, L); (R, R); (L, R); (R, L)\}$$

Step 1: For the pooling strategy (L, L) , go over SR3, SR2R, and SR2S:

SR3: R: Beliefs given S's eq. strategy:

$$\mu(t_1|L) = p = \frac{1}{2} \text{ and } \mu(t_1|R) = q \in [0, 1]$$

SR2R: R: Best response is to play $u|L$ as

$$\mathbb{E}[u_R(L, u|p=\frac{1}{2})] = 0\frac{1}{2} + 3\frac{1}{2} = \frac{3}{2}$$

$$\mathbb{E}[u_R(L, d|p=\frac{1}{2})] = 1\frac{1}{2} + 1\frac{1}{2} = 1$$

SR2S: t_1, t_2 will not deviate if R plays $u|R$.

PBE: Find values of q such that the receiver plays $u|R$.

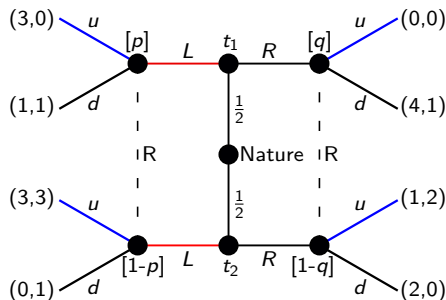

PS11, Ex. 4.b: Signaling games (pooling and separating PBE)

Exercise 4.4.b in Gibbons (p. 248). Describe all the pure-strategy pooling and separating perfect Bayesian equilibria in the following signaling game.

- Consider S's possible strategies:

$$S_S = \{(L, L); (R, R); (L, R); (R, L)\}$$

Step 1: For the pooling strategy (L, L) , go over SR3, SR2R, and SR2S:

SR3: R: Beliefs given S's eq. strategy:

$$\mu(t_1|L) = p = \frac{1}{2} \text{ and } \mu(t_1|R) = q \in [0, 1]$$

SR2R: R: Best response is to play $u|L$ as

$$\mathbb{E}[u_R(L, u|p=\frac{1}{2})] = 0\frac{1}{2} + 3\frac{1}{2} = \frac{3}{2}$$

$$\mathbb{E}[u_R(L, d|p=\frac{1}{2})] = 1\frac{1}{2} + 1\frac{1}{2} = 1$$

SR2S: t_1, t_2 will not deviate if R plays $u|R$.

PBE: Find values of q such that the receiver plays $u|R$:

$$\mathbb{E}[u_R(R, u|q)] \geq \mathbb{E}[u_R(R, d|q)]$$

$$0q + 2[1 - q] \geq 1q + 0[1 - q]$$

$$2 - 2q \geq q$$

$$2 \geq 3q$$

$$\frac{2}{3} \geq q$$

Write up the PBE including beliefs.

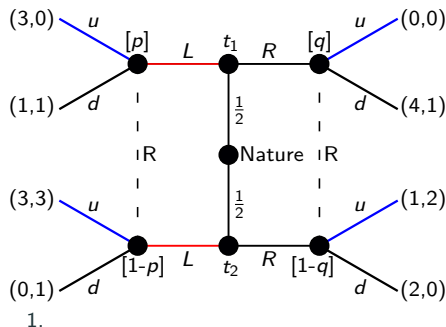

PS11, Ex. 4.b: Signaling games (pooling and separating PBE)

Exercise 4.4.b in Gibbons (p. 248). Describe all the pure-strategy pooling and separating perfect Bayesian equilibria in the following signaling game.

- Consider S's possible strategies:

$$S_S = \{(L, L); (R, R); (L, R); (R, L)\}$$

Step 1: For the pooling strategy (L, L) , go over SR3, SR2R, and SR2S:

SR3: R: Beliefs given S's eq. strategy:

$$\mu(t_1|L) = p = \frac{1}{2} \text{ and } \mu(t_1|R) = q \in [0, 1]$$

SR2R: R: Best response is to play $u|L$ as

$$\mathbb{E}[u_R(L, u|p=\frac{1}{2})] = 0\frac{1}{2} + 3\frac{1}{2} = \frac{3}{2}$$

$$\mathbb{E}[u_R(L, d|p=\frac{1}{2})] = 1\frac{1}{2} + 1\frac{1}{2} = 1$$

SR2S: t_1, t_2 will not deviate if R plays $u|R$.

PBE: Find values of q such that the receiver plays $u|R$:

$$\mathbb{E}[u_R(R, u|q)] \geq \mathbb{E}[u_R(R, d|q)]$$

$$0q + 2[1 - q] \geq 1q + 0[1 - q]$$

$$2 - 2q \geq q$$

$$2 \geq 3q$$

$$\frac{2}{3} \geq q$$

Write up the PBE including beliefs.

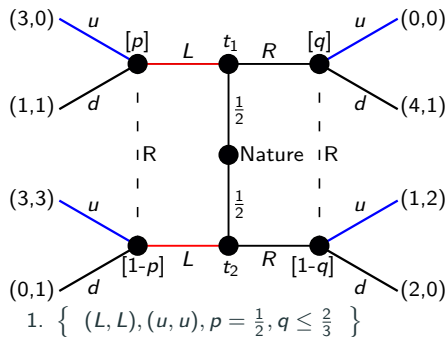

PS11, Ex. 4.b: Signaling games (pooling and separating PBE)

Exercise 4.4.b in Gibbons (p. 248). Describe all the pure-strategy pooling and separating perfect Bayesian equilibria in the following signaling game.

- Consider S's possible strategies:

$$S_S = \{(L, L); (R, R); (L, R); (R, L)\}$$

Step 1: For the pooling strategy (L, L) , go over SR3, SR2R, and SR2S.

Step 2: For the pooling strategy (R, R) , go over SR3, SR2R, and SR2S.

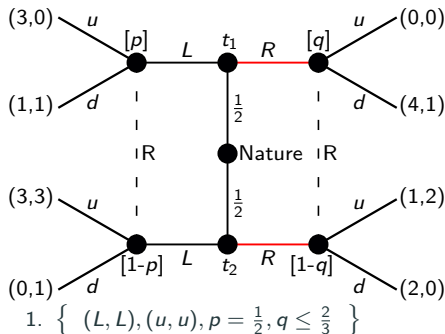

PS11, Ex. 4.b: Signaling games (pooling and separating PBE)

Exercise 4.4.b in Gibbons (p. 248). Describe all the pure-strategy pooling and separating perfect Bayesian equilibria in the following signaling game.

- Consider S 's possible strategies:

$$S_S = \{(L, L); (R, R); (L, R); (R, L)\}$$

Step 1: For the pooling strategy (L, L) , go over SR3, SR2R, and SR2S.

Step 2: For the pooling strategy (R, R) , go over SR3, SR2R, and SR2S:

SR3: R: Beliefs given S 's eq. strategy:

$$\mu(t_1|L) = p \in [0, 1] \text{ and } \mu(t_1|R) = q = \frac{1}{2}$$

SR2R: R: Best response is to play u as

$$\mathbb{E}[u_R(R, u|q=\frac{1}{2})] = 0\frac{1}{2} + 2\frac{1}{2} = 1$$

$$\mathbb{E}[u_R(R, d|q=\frac{1}{2})] = 1\frac{1}{2} + 0\frac{1}{2} = \frac{1}{2}$$

SR2S: t_1 will deviate as the payoff from $(L, a(L)|t_1)$ is strictly higher than $(R, u|t_1) = 0$.

PBE: No PBE, as t_1 wants to deviate.

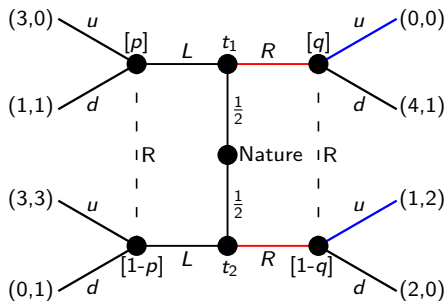

- $\{ (L, L), (u, u), p = \frac{1}{2}, q \leq \frac{2}{3} \}$
- No PBE that includes (R, R) .

PS11, Ex. 4.b: Signaling games (pooling and separating PBE)

Exercise 4.4.b in Gibbons (p. 248). Describe all the pure-strategy pooling and separating perfect Bayesian equilibria in the following signaling game.

- Consider S 's possible strategies:

$$S_S = \{(L, L); (R, R); (L, R); (R, L)\}$$

Step 1: For the pooling strategy (L, L) , go over SR3, SR2R, and SR2S.

Step 2: For the pooling strategy (R, R) , go over SR3, SR2R, and SR2S.

Step 3: **For the separating strategy (L, R) , go over SR3, SR2R, and SR2S.**

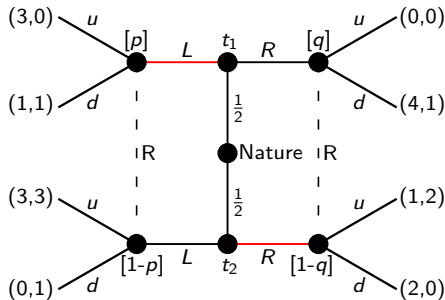

- $\left\{ (L, L), (u, u), p = \frac{1}{2}, q \leq \frac{2}{3} \right\}$
- No PBE that includes (R, R) .

PS11, Ex. 4.b: Signaling games (pooling and separating PBE)

Exercise 4.4.b in Gibbons (p. 248). Describe all the pure-strategy pooling and separating perfect Bayesian equilibria in the following signaling game.

- Consider S's possible strategies:

$$S_S = \{(L, L); (R, R); (L, R); (R, L)\}$$

Step 1: For the pooling strategy (L, L) , go over SR3, SR2R, and SR2S.

Step 2: For the pooling strategy (R, R) , go over SR3, SR2R, and SR2S.

Step 3: For the separating strategy (L, R) , go over SR3, SR2R, and SR2S:

SR3: R: Beliefs given S's eq. strategy:

$$\mu(t_1|L) = p = 1 \text{ and } \mu(t_1|R) = q = 0$$

SR2R: R: Best response is to play $d|L, u|R$.

SR2S: t_1 will not deviate as

$$u_S(L, d|t_1) = 1 > 0 = u_S(R, u|t_1)$$

t_2 will not deviate as

$$u_S(R, u|t_2) = 1 > 0 = u_S(L, d|t_2)$$

PBE: No deviation, thus, it's a PBE.

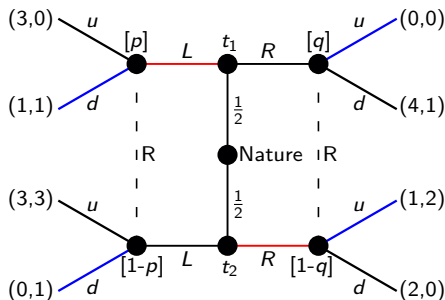

- $\{ (L, L), (u, u), p = \frac{1}{2}, q \leq \frac{2}{3} \}$
- No PBE that includes (R, R) .
- $\{ (L, R), (d, u), p = 1, q = 0 \}$

PS11, Ex. 4.b: Signaling games (pooling and separating PBE)

Exercise 4.4.b in Gibbons (p. 248). Describe all the pure-strategy pooling and separating perfect Bayesian equilibria in the following signaling game.

- Consider S 's possible strategies:

$$S_S = \{(L, L); (R, R); (L, R); (R, L)\}$$

Step 1: For the pooling strategy (L, L) , go over SR3, SR2R, and SR2S.

Step 2: For the pooling strategy (R, R) , go over SR3, SR2R, and SR2S.

Step 3: For the separating strategy (L, R) , go over SR3, SR2R, and SR2S.

Step 4: **For the separating strategy (R, L) , go over SR3, SR2R, and SR2S.**

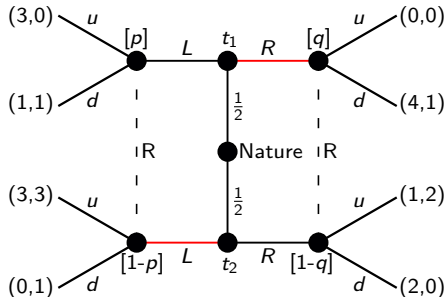

- $\left\{ (L, L), (u, u), p = \frac{1}{2}, q \leq \frac{2}{3} \right\}$
- No PBE that includes (R, R) .
- $\left\{ (L, R), (d, u), p = 1, q = 0 \right\}$

PS11, Ex. 4.b: Signaling games (pooling and separating PBE)

Exercise 4.4.b in Gibbons (p. 248). Describe all the pure-strategy pooling and separating perfect Bayesian equilibria in the following signaling game.

- Consider S 's possible strategies:

$$S_S = \{(L, L); (R, R); (L, R); (R, L)\}$$

Step 1: For the pooling strategy (L, L) , go over SR3, SR2R, and SR2S.

Step 2: For the pooling strategy (R, R) , go over SR3, SR2R, and SR2S.

Step 3: For the separating strategy (L, R) , go over SR3, SR2R, and SR2S.

Step 4: For the separating strategy (R, L) , go over SR3, SR2R, and SR2S:

SR3: R: Beliefs given S 's eq. strategy:

$$\mu(t_1|L) = p = 0 \text{ and } \mu(t_1|R) = q = 1$$

SR2R: R: Best response is to play $u|L, d|R$.

SR2S: t_1 will not deviate as

$$u_S(R, d|t_1) = 4 > 3 = u_S(L, u|t_1)$$

t_2 will not deviate as

$$u_S(L, u|t_2) = 3 > 2 = u_S(R, d|t_2)$$

PBE: No deviation, thus, it's a PBE.

Step 5: **Write up the full set of PBE.**

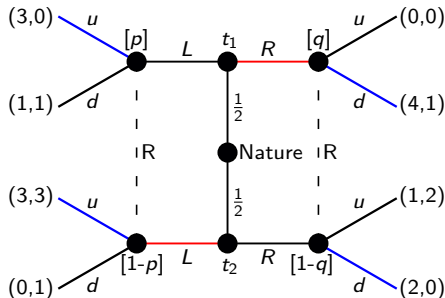

- $\{ (L, L), (u, u), p = \frac{1}{2}, q \leq \frac{2}{3} \}$
- No PBE that includes (R, R) .
- $\{ (L, R), (d, u), p = 1, q = 0 \}$
- $\{ (R, L), (u, d), p = 0, q = 1 \}$

PS11, Ex. 4.b: Signaling games (pooling and separating PBE)

Exercise 4.4.b in Gibbons (p. 248). Describe all the pure-strategy pooling and separating perfect Bayesian equilibria in the following signaling game.

- Consider S's possible strategies:

$$S_S = \{(L, L); (R, R); (L, R); (R, L)\}$$

Step 1: For the pooling strategy (L, L) , go over SR3, SR2R, and SR2S.

Step 2: For the pooling strategy (R, R) , go over SR3, SR2R, and SR2S.

Step 3: For the separating strategy (L, R) , go over SR3, SR2R, and SR2S.

Step 4: For the separating strategy (R, L) , go over SR3, SR2R, and SR2S:

Step 5: Write up the full set of PBE.

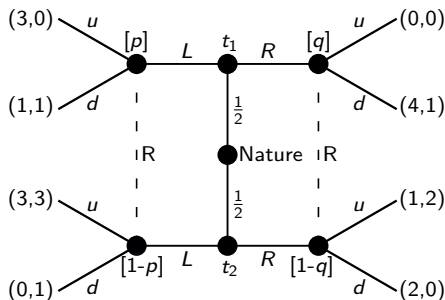

- $\left\{ (L, L), (u, u), p = \frac{1}{2}, q \leq \frac{2}{3} \right\}$
- No PBE that includes (R, R) .
- $\left\{ (L, R), (d, u), p = 1, q = 0 \right\}$
- $\left\{ (R, L), (u, d), p = 0, q = 1 \right\}$
- $\left\{ \begin{array}{l} (L, L), (u, u), p = \frac{1}{2}, q \leq \frac{2}{3} \\ (L, R), (d, u), p = 1, q = 0 \\ (R, L), (u, d), p = 0, q = 1 \end{array} \right\}$

**PS11, Ex. 5: Signaling games
(pooling PBE)**

PS11, Ex. 5.a: Signaling games (pooling PBE)

Exercise 4.3.a in Gibbons (p. 246). Specify a pooling perfect Bayesian equilibria in which both Sender types play R in the following signaling game.

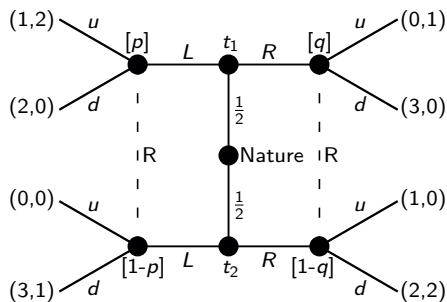

PS11, Ex. 5.a: Signaling games (pooling PBE)

Exercise 4.3.a in Gibbons (p. 246). Specify a pooling perfect Bayesian equilibria in which both Sender types play R in the following signaling game.

For the pooling strategy (R,R) , go over SR3, SR2R, and SR2S.

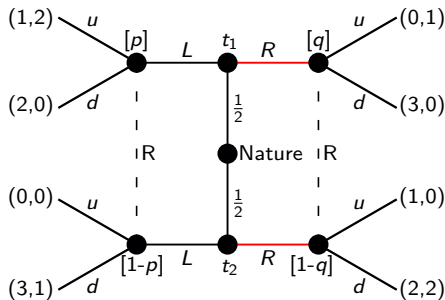

PS11, Ex. 5.a: Signaling games (pooling PBE)

Exercise 4.3.a in Gibbons (p. 246). Specify a pooling perfect Bayesian equilibria in which both Sender types play R in the following signaling game.

For the pooling strategy (R,R) , go over SR3, SR2R, and SR2S:

SR3: R: Beliefs given S's eq. strategy:

$$\mu(t_1|L) = p \in [0, 1] \text{ and } \mu(t_1|R) = q = \frac{1}{2}$$

SR2R: R: Best response is to play d as

$$\mathbb{E}[u_R(R, u|q=\frac{1}{2})] = 1\frac{1}{2} + 0\frac{1}{2} = \frac{1}{2}$$

$$\mathbb{E}[u_R(R, d|q=\frac{1}{2})] = 0\frac{1}{2} + 2\frac{1}{2} = 1$$

SR2S: t_1 will not deviate as

$$u_S(R, d|t_1) = 3 > 1 = u_S(L, u|t_1)$$

$$u_S(R, d|t_1) = 3 > 2 = u_S(L, d|t_1)$$

t_2 will deviate if $a(L) = d$ (as $2 < 3$) but not if $a(L) = u$ (as $2 > 0$).

PBE: Find the off-equilibrium beliefs p for which R plays $a^*(L) = u$.

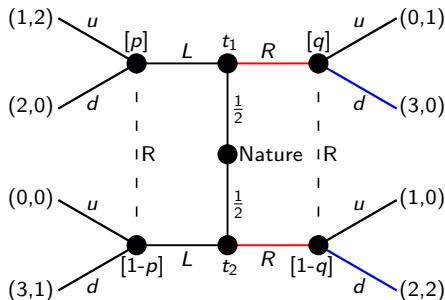

PS11, Ex. 5.a: Signaling games (pooling PBE)

Exercise 4.3.a in Gibbons (p. 246). Specify a pooling perfect Bayesian equilibria in which both Sender types play R in the following signaling game.

For the pooling strategy (R,R) , go over SR3, SR2R, and SR2S:

SR3: R: Beliefs given S's eq. strategy:

$$\mu(t_1|L) = p \in [0, 1] \text{ and } \mu(t_1|R) = q = \frac{1}{2}$$

SR2R: R: Best response is to play d as

$$\mathbb{E}[u_R(R, u|q=\frac{1}{2})] = 1\frac{1}{2} + 0\frac{1}{2} = \frac{1}{2}$$

$$\mathbb{E}[u_R(R, d|q=\frac{1}{2})] = 0\frac{1}{2} + 2\frac{1}{2} = 1$$

SR2S: t_1 will not deviate as

$$u_S(R, d|t_1) = 3 > 1 = u_S(L, u|t_1)$$

$$u_S(R, d|t_1) = 3 > 2 = u_S(L, d|t_1)$$

t_2 will deviate if $a(L) = d$ (as $2 < 3$) but not if $a(L) = u$ (as $2 > 0$).

PBE: Find the off-equilibrium beliefs p for which R plays $a^*(L) = u$:

$$\mathbb{E}[u_R(L, u|p)] \geq \mathbb{E}[u_R(L, d|p)]$$

$$2p \geq 1 - p$$

$$3p \geq 1$$

$$p \geq \frac{1}{3}$$

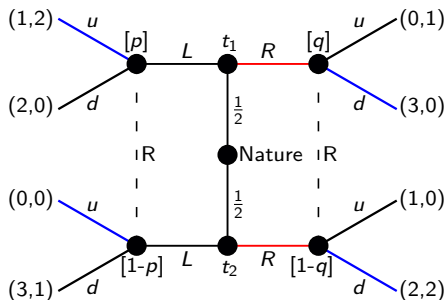

Write up the PBE.

PS11, Ex. 5.a: Signaling games (pooling PBE)

Exercise 4.3.a in Gibbons (p. 246). Specify a pooling perfect Bayesian equilibria in which both Sender types play R in the following signaling game.

For the pooling strategy (R,R) , go over SR3, SR2R, and SR2S:

SR3: R: Beliefs given S's eq. strategy:

$$\mu(t_1|L) = p \in [0, 1] \text{ and } \mu(t_1|R) = q = \frac{1}{2}$$

SR2R: R: Best response is to play d as

$$\mathbb{E}[u_R(R, u|q=\frac{1}{2})] = 1\frac{1}{2} + 0\frac{1}{2} = \frac{1}{2}$$

$$\mathbb{E}[u_R(R, d|q=\frac{1}{2})] = 0\frac{1}{2} + 2\frac{1}{2} = 1$$

SR2S: t_1 will not deviate as

$$u_S(R, d|t_1) = 3 > 1 = u_S(L, u|t_1)$$

$$u_S(R, d|t_1) = 3 > 2 = u_S(L, d|t_1)$$

t_2 will deviate if $a(L) = d$ (as $2 < 3$) but not if $a(L) = u$ (as $2 > 0$).

PBE: Find the off-equilibrium beliefs p for which R plays $a^*(L) = u$:

$$\mathbb{E}[u_R(L, u|p)] \geq \mathbb{E}[u_R(L, d|p)]$$

$$2p \geq 1 - p$$

$$3p \geq 1$$

$$p \geq \frac{1}{3}$$

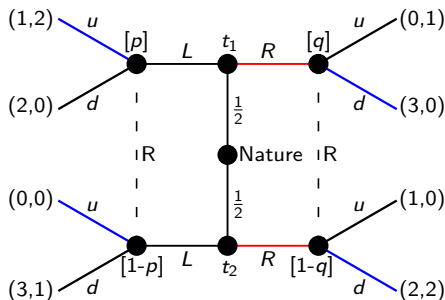

Write up the PBE:

$$\left\{ (R, R), (u, d), p \geq \frac{1}{3}, q = \frac{1}{2} \right\}$$

PS11, Ex. 5.b: Signaling games (pooling PBE)

Exercise 4.3.b in Gibbons (p. 246). The following three-type signaling game begins with a move by nature, not shown in the tree, that yields one of the three types with equal probability. Specify a pooling perfect Bayesian equilibria in which all three Sender types play L .

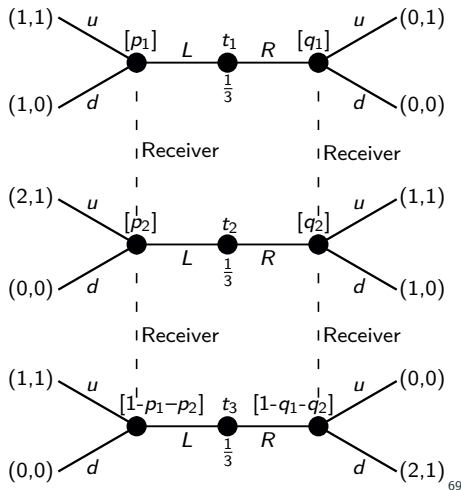

PS11, Ex. 5.b: Signaling games (pooling PBE)

Exercise 4.3.b in Gibbons (p. 246). The following three-type signaling game begins with a move by nature, not shown in the tree, that yields one of the three types with equal probability. Specify a pooling PBE in which all three Sender types play L .

For the pooling strategy (L,L,L) , go over SR3, SR2R, and SR2S.

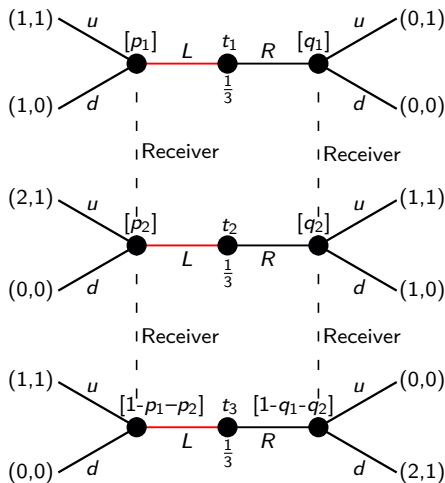

PS11, Ex. 5.b: Signaling games (pooling PBE)

Exercise 4.3.b in Gibbons (p. 246). The following three-type signaling game begins with a move by nature, not shown in the tree, that yields one of the three types with equal probability. Specify a pooling PBE in which all three Sender types play L .

For the pooling strategy (L,L,L) , go over SR3, SR2R, and SR2S:

SR3: R: Beliefs given S's eq. strategy:

$$\mu(t_1|L) \equiv p_1 = \frac{1}{3} = p_2 \equiv \mu(t_2|L)$$

$$\mu(t_1|R) = q_1 \in [0, 1]$$

$$\mu(t_2|R) = q_1 \in [0, 1 - q_1]$$

SR2R: R: Best response is to play $u|L$ as

$$\mathbb{E}[u_R(L, u)] = 1\frac{1}{3} + 1\frac{1}{3} + 1\frac{1}{3} = 1$$

$$\mathbb{E}[u_R(L, d)] = 0\frac{1}{3} + 0\frac{1}{3} + 0\frac{1}{3} = 0$$

SR2S: t_1 will never deviate as $L|t_1$ strictly dominates $R|t_1$.

t_2 will not deviate ($2 > 1$, $2 > 1$).

t_3 will not deviate if R plays $a(R) = u$.

PBE: Find the off-equilibrium beliefs q_1, q_2 for which R plays $a^*(R) = u$.

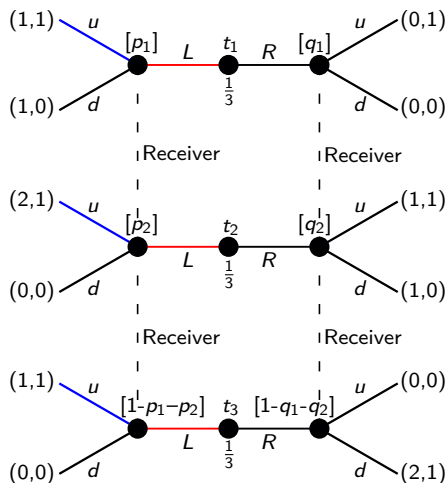

PS11, Ex. 5.b: Signaling games (pooling PBE)

Exercise 4.3.b in Gibbons (p. 246). Find a PBE in which all three Sender types play L .

For the pooling strategy (L, L, L) , go over SR3, SR2R, and SR2S:

SR3: R: Beliefs given S's eq. strategy:

$$\mu(t_1|L) \equiv p_1 = \frac{1}{3} = p_2 \equiv \mu(t_2|L)$$

$$\mu(t_1|R) = q_1 \in [0, 1]$$

$$\mu(t_2|R) = q_1 \in [0, 1 - q_1]$$

SR2R: R: Best response is to play $u|L$ as

$$\mathbb{E}[u_R(L, u)] = 1\frac{1}{3} + 1\frac{1}{3} + 1\frac{1}{3} = 1$$

$$\mathbb{E}[u_R(L, d)] = 0\frac{1}{3} + 0\frac{1}{3} + 0\frac{1}{3} = 0$$

SR2S: t_1 will never deviate as $L|t_1$ strictly dominates $R|t_1$.

t_2 will not deviate ($2 > 1, 2 > 1$).

t_3 will not deviate if R plays $a(R) = u$.

PBE: Find the off-equilibrium beliefs q_1, q_2

for which R plays $a^*(R) = u$:

$$\mathbb{E}[u_R(R, u)] \geq \mathbb{E}[u_R(R, d)]$$

$$1q_1 + 1q_2 \geq 1(1 - q_1 - q_2)$$

$$2q_1 + 2q_2 \geq 1$$

$$q_1 + q_2 \geq \frac{1}{2}$$

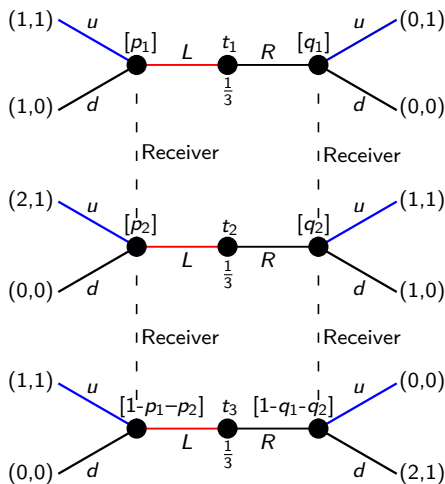

Write up the PBE with pooling on L

PS11, Ex. 5.b: Signaling games (pooling PBE)

Exercise 4.3.b in Gibbons (p. 246). Find a PBE in which all three Sender types play L .

For the pooling strategy (L, L, L) , go over SR3, SR2R, and SR2S:

SR3: R: Beliefs given S's eq. strategy:

$$\mu(t_1|L) \equiv p_1 = \frac{1}{3} = p_2 \equiv \mu(t_2|L)$$

$$\mu(t_1|R) = q_1 \in [0, 1]$$

$$\mu(t_2|R) = q_1 \in [0, 1 - q_1]$$

SR2R: R: Best response is to play $u|L$ as

$$\mathbb{E}[u_R(L, u)] = 1 \cdot \frac{1}{3} + 1 \cdot \frac{1}{3} + 1 \cdot \frac{1}{3} = 1$$

$$\mathbb{E}[u_R(L, d)] = 0 \cdot \frac{1}{3} + 0 \cdot \frac{1}{3} + 0 \cdot \frac{1}{3} = 0$$

SR2S: t_1 will never deviate as $L|t_1$ strictly dominates $R|t_1$.

t_2 will not deviate ($2 > 1, 2 > 1$).

t_3 will not deviate if R plays $a(R) = u$.

PBE: Find the off-equilibrium beliefs q_1, q_2

for which R plays $a^*(R) = u$:

$$\mathbb{E}[u_R(R, u)] \geq \mathbb{E}[u_R(R, d)]$$

$$1q_1 + 1q_2 \geq 1(1 - q_1 - q_2)$$

$$2q_1 + 2q_2 \geq 1$$

$$q_1 + q_2 \geq \frac{1}{2}$$

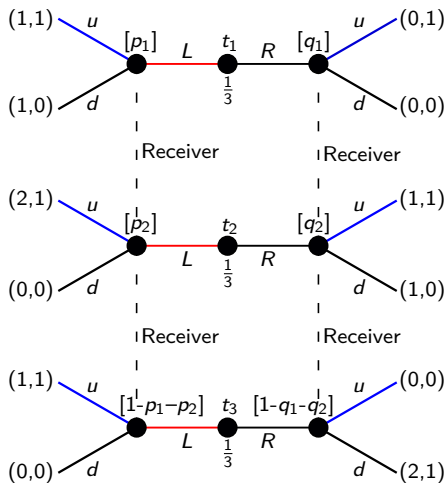

Write up the PBE with pooling on L : $\left\{ (L, L, L), (u, u), p_1 = p_2 = \frac{1}{3}, q_1 + q_2 \geq \frac{1}{2} \right\}$

**PS11, Ex. 6: Spence's education
signaling model (pooling and
separating PBE)**

PS11, Ex. 6: Spence's education signaling model (PBE)

Consider the following version of Spence's education signaling model, where a firm is hiring a worker. Workers is characterized by their type θ , which measures their ability. There are two worker types: $\theta \in \{\theta_L, \theta_H\}$. Nature chooses the worker's type, with $p_H = \mathbb{P}[\theta = \theta_H]$ and $p_L = \mathbb{P}[\theta = \theta_L] = 1 - p_H$.

The worker observes his own type, but the firm does not. The worker can choose his level of education: $e \in \mathbb{R}^+$. The cost to him of acquiring this education is $c_\theta(e) = e/\theta$. Education is observed by the firm, who then forms beliefs about the workers type: $\mu(\theta|e)$. We assume that the marginal productivity of a worker is equal to his ability and that the company is in competition such it pays the marginal productivity: $w(e) = \mathbb{E}[\theta|e]$. Thus, the payoff to a worker conditional on his type and education is $u_\theta(e) = w(e) - c_\theta(e)$. Suppose for this exercise that $\theta_H = 3$ and $\theta_L = 1$.

- (a) Find a separating pure strategy Perfect Bayesian Equilibrium.
- (b) Find a pooling pure strategy Perfect Bayesian Equilibrium.

(a) Find a separating pure strategy Perfect Bayesian Equilibrium.

Step 1: **Specify on-equilibrium path beliefs** (determined by Bayes' rule).

Types: $\theta \in \{\theta_L, \theta_H\}$, $\theta_H = 3$ and $\theta_L = 1$
Prob.: $p_H = \mathbb{P}[\theta = \theta_H]$ and $p_L = 1 - p_H$
Wage: $w(e) = \mathbb{E}[\theta|e]$
Cost: $c_\theta(e) = e/\theta$
Utility: $u_\theta(e) = w(e) - c_\theta(e)$

(a) Find a separating pure strategy Perfect Bayesian Equilibrium.

Step 1: Specify on-equilibrium path beliefs
(determined by Bayes' rule).

Types: $\theta \in \{\theta_L, \theta_H\}$, $\theta_H = 3$ and $\theta_L = 1$

Prob.: $p_H = \mathbb{P}[\theta = \theta_H]$ and $p_L = 1 - p_H$

Wage: $w(e) = \mathbb{E}[\theta|e]$

Cost: $c_\theta(e) = e/\theta$

Utility: $u_\theta(e) = w(e) - c_\theta(e)$

- $\mu(\theta_H|e_H^*) = \mathbb{P}[\theta = \theta_H|e_H^*] = 1$
 $\mu(\theta_L|e_L^*) = \mathbb{P}[\theta = \theta_L|e_L^*] = 1$

(a) Find a separating pure strategy Perfect Bayesian Equilibrium.

- Step 1: Specify on-equilibrium path beliefs (determined by Bayes' rule).
 Types: $\theta \in \{\theta_L, \theta_H\}$, $\theta_H = 3$ and $\theta_L = 1$
 Prob.: $p_H = \mathbb{P}[\theta = \theta_H]$ and $p_L = 1 - p_H$
- Step 2: **Specify off-equilibrium path beliefs where any deviation is believed to be by a low type.**
 Wage: $w(e) = \mathbb{E}[\theta|e]$
 Cost: $c_\theta(e) = e/\theta$
 Utility: $u_\theta(e) = w(e) - c_\theta(e)$
1. $\mu(\theta_H|e_H^*) = \mathbb{P}[\theta = \theta_H|e_H^*] = 1$
 $\mu(\theta_L|e_L^*) = \mathbb{P}[\theta = \theta_L|e_L^*] = 1$

(a) Find a separating pure strategy Perfect Bayesian Equilibrium.

- Step 1: Specify on-equilibrium path beliefs (determined by Bayes' rule). Types: $\theta \in \{\theta_L, \theta_H\}$, $\theta_H = 3$ and $\theta_L = 1$
 Prob.: $p_H = \mathbb{P}[\theta = \theta_H]$ and $p_L = 1 - p_H$
- Step 2: Specify off-equilibrium path beliefs where any deviation is believed to be by a low type. Wage: $w(e) = \mathbb{E}[\theta|e]$
 Cost: $c_\theta(e) = e/\theta$
 Utility: $u_\theta(e) = w(e) - c_\theta(e)$
- $$\mu(\theta_H|e_H^*) = \mathbb{P}[\theta = \theta_H|e_H^*] = 1$$

$$\mu(\theta_L|e_L^*) = \mathbb{P}[\theta = \theta_L|e_L^*] = 1$$
 - $$\mu^*(\theta_H|e) = \begin{cases} 1, & e = e_H^* \\ 0, & e \neq e_H^* \end{cases}$$

(a) Find a separating pure strategy Perfect Bayesian Equilibrium.

- Step 1: Specify on-equilibrium path beliefs (determined by Bayes' rule). Types: $\theta \in \{\theta_L, \theta_H\}$, $\theta_H = 3$ and $\theta_L = 1$
 Prob.: $p_H = \mathbb{P}[\theta = \theta_H]$ and $p_L = 1 - p_H$
- Step 2: Specify off-equilibrium path beliefs where any deviation is believed to be by a low type. Wage: $w(e) = \mathbb{E}[\theta|e]$
 Cost: $c_\theta(e) = e/\theta$
- Step 3: **Write up the wage function under competition (implied by the beliefs).** Utility: $u_\theta(e) = w(e) - c_\theta(e)$
- $\mu(\theta_H|e_H^*) = \mathbb{P}[\theta = \theta_H|e_H^*] = 1$
 $\mu(\theta_L|e_L^*) = \mathbb{P}[\theta = \theta_L|e_L^*] = 1$
 - $\mu^*(\theta_H|e) = \begin{cases} 1, & e = e_H^* \\ 0, & e \neq e_H^* \end{cases}$

PS11, Ex. 6.a: Spence's education signaling model (separating PBE)

(a) Find a separating pure strategy Perfect Bayesian Equilibrium.

- Step 1: Specify on-equilibrium path beliefs (determined by Bayes' rule). Types: $\theta \in \{\theta_L, \theta_H\}$, $\theta_H = 3$ and $\theta_L = 1$
Prob.: $p_H = \mathbb{P}[\theta = \theta_H]$ and $p_L = 1 - p_H$
- Step 2: Specify off-equilibrium path beliefs where any deviation is believed to be by a low type. Wage: $w(e) = \mathbb{E}[\theta|e]$
Cost: $c_\theta(e) = e/\theta$
- Step 3: Write up the wage function under competition (implied by the beliefs). Utility: $u_\theta(e) = w(e) - c_\theta(e)$
- $\mu(\theta_H|e_H^*) = \mathbb{P}[\theta = \theta_H|e_H^*] = 1$
 $\mu(\theta_L|e_L^*) = \mathbb{P}[\theta = \theta_L|e_L^*] = 1$
 - $\mu^*(\theta_H|e) = \begin{cases} 1, & e = e_H^* \\ 0, & e \neq e_H^* \end{cases}$
 - $w^*(e) = \begin{cases} 3, & e = e_H^* \\ 1, & e \neq e_H^* \end{cases}$

PS11, Ex. 6.a: Spence's education signaling model (separating PBE)

(a) Find a separating pure strategy Perfect Bayesian Equilibrium.

- Step 1: Specify on-equilibrium path beliefs (determined by Bayes' rule). Types: $\theta \in \{\theta_L, \theta_H\}$, $\theta_H = 3$ and $\theta_L = 1$
 Prob.: $p_H = \mathbb{P}[\theta = \theta_H]$ and $p_L = 1 - p_H$
- Step 2: Specify off-equilibrium path beliefs where any deviation is believed to be by a low type. Wage: $w(e) = \mathbb{E}[\theta|e]$
 Cost: $c_\theta(e) = e/\theta$
- Step 3: Write up the wage function under competition (implied by the beliefs). Utility: $u_\theta(e) = w(e) - c_\theta(e)$
- Step 4: **Find e_H^* , e_L^* such that low types will not imitate high types (ICC - Incentive Compatibility Constraint).**
- $\mu(\theta_H|e_H^*) = \mathbb{P}[\theta = \theta_H|e_H^*] = 1$
 $\mu(\theta_L|e_L^*) = \mathbb{P}[\theta = \theta_L|e_L^*] = 1$
 - $\mu^*(\theta_H|e) = \begin{cases} 1, & e = e_H^* \\ 0, & e \neq e_H^* \end{cases}$
 - $w^*(e) = \begin{cases} 3, & e = e_H^* \\ 1, & e \neq e_H^* \end{cases}$

PS11, Ex. 6.a: Spence's education signaling model (separating PBE)

(a) Find a separating pure strategy Perfect Bayesian Equilibrium.

Step 1: Specify on-equilibrium path beliefs (determined by Bayes' rule). Types: $\theta \in \{\theta_L, \theta_H\}$, $\theta_H = 3$ and $\theta_L = 1$
 Prob.: $p_H = \mathbb{P}[\theta = \theta_H]$ and $p_L = 1 - p_H$

Step 2: Specify off-equilibrium path beliefs where any deviation is believed to be by a low type. Wage: $w(e) = \mathbb{E}[\theta|e]$
 Cost: $c_\theta(e) = e/\theta$

Step 3: Write up the wage function under competition (implied by the beliefs).

Utility: $u_\theta(e) = w(e) - c_\theta(e)$

Step 4: Find e_H^*, e_L^* such that low types will not imitate high types (ICC - Incentive Compatibility Constraint):

$$1. \mu(\theta_H|e_H^*) = \mathbb{P}[\theta = \theta_H|e_H^*] = 1$$

$$\mu(\theta_L|e_L^*) = \mathbb{P}[\theta = \theta_L|e_L^*] = 1$$

$$2. \mu^*(\theta_H|e) = \begin{cases} 1, & e = e_H^* \\ 0, & e \neq e_H^* \end{cases}$$

$$3. w^*(e) = \begin{cases} 3, & e = e_H^* \\ 1, & e \neq e_H^* \end{cases}$$

$$4. e_H^* - e_L^* \geq 2$$

$$w(e_L^*) - c_{\theta_L}(e_L^*) \geq w(e_H^*) - c_{\theta_L}(e_H^*)$$

$$\theta_L - \frac{e_L^*}{\theta_L} \geq \theta_H - \frac{e_H^*}{\theta_L}$$

$$1 - \frac{e_L^*}{1} \geq 3 - \frac{e_H^*}{1}$$

$$e_L^* \geq 2 - e_H^*$$

$$e_H^* - e_L^* \geq 2$$

Step 5: Find e_H^*, e_L^* such that high types will not deviate (ICC).

PS11, Ex. 6.a: Spence's education signaling model (separating PBE)

(a) Find a separating pure strategy Perfect Bayesian Equilibrium.

Step 1: Specify on-equilibrium path beliefs (determined by Bayes' rule).
Types: $\theta \in \{\theta_L, \theta_H\}$, $\theta_H = 3$ and $\theta_L = 1$
Prob.: $p_H = \mathbb{P}[\theta = \theta_H]$ and $p_L = 1 - p_H$

Step 2: Specify off-equilibrium path beliefs where any deviation is believed to be by a low type.
Wage: $w(e) = \mathbb{E}[\theta|e]$
Cost: $c_\theta(e) = e/\theta$

Step 3: Write up the wage function under competition (implied by the beliefs).
Utility: $u_\theta(e) = w(e) - c_\theta(e)$

Step 4: Find e_H^*, e_L^* such that low types will not imitate high types (ICC - Incentive Compatibility Constraint).

Step 5: Find e_H^*, e_L^* such that high types will not deviate (ICC):

$$w(e_H^*) - c_{\theta_H}(e_H^*) \geq w(e_L^*) - c_{\theta_H}(e_L^*)$$

$$\theta_H - \frac{e_H^*}{\theta_H} \geq \theta_L - \frac{e_L^*}{\theta_H}$$

$$3 - \frac{e_H^*}{3} \geq 1 - \frac{e_L^*}{3}$$

$$2 \geq \frac{e_H^* - e_L^*}{3}$$

$$6 \geq e_H^* - e_L^*$$

$$1. \mu(\theta_H|e_H^*) = \mathbb{P}[\theta = \theta_H|e_H^*] = 1$$

$$\mu(\theta_L|e_L^*) = \mathbb{P}[\theta = \theta_L|e_L^*] = 1$$

$$2. \mu^*(\theta_H|e) = \begin{cases} 1, & e = e_H^* \\ 0, & e \neq e_H^* \end{cases}$$

$$3. w^*(e) = \begin{cases} 3, & e = e_H^* \\ 1, & e \neq e_H^* \end{cases}$$

$$4. e_H^* - e_L^* \geq 2$$

$$5. e_H^* - e_L^* \leq 6 \Rightarrow e_H^* - e_L^* \in [2, 6]$$

PS11, Ex. 6.a: Spence's education signaling model (separating PBE)

(a) Find a separating pure strategy Perfect Bayesian Equilibrium.

- | | |
|-------------------------------------------------------------------------------------------------------------------------|-----------------------------------------------------------------------------------------------------------------------------------------------------------------------------------------------------------------------------------------------------------------------------------------------------------------------------------|
| Step 1: Specify on-equilibrium path beliefs (determined by Bayes' rule). | Types: $\theta \in \{\theta_L, \theta_H\}$, $\theta_H = 3$ and $\theta_L = 1$
Prob.: $p_H = \mathbb{P}[\theta = \theta_H]$ and $p_L = 1 - p_H$ |
| Step 2: Specify off-equilibrium path beliefs where any deviation is believed to be by a low type. | Wage: $w(e) = \mathbb{E}[\theta e]$
Cost: $c_\theta(e) = e/\theta$ |
| Step 3: Write up the wage function under competition (implied by the beliefs). | Utility: $u_\theta(e) = w(e) - c_\theta(e)$ |
| Step 4: Find e_H^*, e_L^* such that low types will not imitate high types (ICC - Incentive Compatibility Constraint). | <ol style="list-style-type: none"> 1. $\mu(\theta_H e_H^*) = \mathbb{P}[\theta = \theta_H e_H^*] = 1$
$\mu(\theta_L e_L^*) = \mathbb{P}[\theta = \theta_L e_L^*] = 1$ 2. $\mu^*(\theta_H e) = \begin{cases} 1, & e = e_H^* \\ 0, & e \neq e_H^* \end{cases}$ |
| Step 5: Find e_H^*, e_L^* such that high types will not deviate (ICC): | <ol style="list-style-type: none"> 3. $w^*(e) = \begin{cases} 3, & e = e_H^* \\ 1, & e \neq e_H^* \end{cases}$ |
| Step 6: Which level of e_L^* does θ_L choose? | <ol style="list-style-type: none"> 4. $e_H^* - e_L^* \geq 2$ 5. $e_H^* - e_L^* \leq 6 \Rightarrow e_H^* - e_L^* \in [2, 6]$ |

PS11, Ex. 6.a: Spence's education signaling model (separating PBE)

(a) Find a separating pure strategy Perfect Bayesian Equilibrium.

- Step 1: Specify on-equilibrium path beliefs (determined by Bayes' rule). Types: $\theta \in \{\theta_L, \theta_H\}$, $\theta_H = 3$ and $\theta_L = 1$
 Prob.: $p_H = \mathbb{P}[\theta = \theta_H]$ and $p_L = 1 - p_H$
- Step 2: Specify off-equilibrium path beliefs where any deviation is believed to be by a low type. Wage: $w(e) = \mathbb{E}[\theta|e]$
 Cost: $c_\theta(e) = e/\theta$
- Step 3: Write up the wage function under competition (implied by the beliefs). Utility: $u_\theta(e) = w(e) - c_\theta(e)$
- Step 4: Find e_H^*, e_L^* such that low types will not imitate high types (ICC - Incentive Compatibility Constraint).
- Step 5: Find e_H^*, e_L^* such that high types will not deviate (ICC):
- Step 6: Which level of e_L^* does θ_L choose?
- The productivity, and thus the wage, is the same for all levels of education when the incentives (ICCs) are satisfied. But education is costly for the worker.
- Step 7: **Write up the PBE given beliefs.**
- $\mu(\theta_H|e_H^*) = \mathbb{P}[\theta = \theta_H|e_H^*] = 1$
 $\mu(\theta_L|e_L^*) = \mathbb{P}[\theta = \theta_L|e_L^*] = 1$
 - $\mu^*(\theta_H|e) = \begin{cases} 1, & e = e_H^* \\ 0, & e \neq e_H^* \end{cases}$
 - $w^*(e) = \begin{cases} 3, & e = e_H^* \\ 1, & e \neq e_H^* \end{cases}$
 - $e_H^* - e_L^* \geq 2$
 - $e_H^* - e_L^* \leq 6 \Rightarrow e_H^* - e_L^* \in [2, 6]$
 - $e_L^* = 0$ is the cost-minimizing effort.

PS11, Ex. 6.a: Spence's education signaling model (separating PBE)

(a) Find a separating pure strategy Perfect Bayesian Equilibrium.

- Step 1: Specify on-equilibrium path beliefs (determined by Bayes' rule). Types: $\theta \in \{\theta_L, \theta_H\}$, $\theta_H = 3$ and $\theta_L = 1$
 Prob.: $p_H = \mathbb{P}[\theta = \theta_H]$ and $p_L = 1 - p_H$
- Step 2: Specify off-equilibrium path beliefs where any deviation is believed to be by a low type. Wage: $w(e) = \mathbb{E}[\theta|e]$
 Cost: $c_\theta(e) = e/\theta$
- Step 3: Write up the wage function under competition (implied by the beliefs). Utility: $u_\theta(e) = w(e) - c_\theta(e)$
- Step 4: Find e_H^*, e_L^* such that low types will not imitate high types (ICC - Incentive Compatibility Constraint).
- Step 5: Find e_H^*, e_L^* such that high types will not deviate (ICC):
- Step 6: Which level of e_L^* does θ_L choose?
 The productivity, and thus the wage, is the same for all levels of education when the incentives (ICCs) are satisfied. But education is costly for the worker.
- Step 7: Write up the PBE given beliefs.
- Step 8: **Which e_H^* is cost-minimizing?**
- $\mu(\theta_H|e_H^*) = \mathbb{P}[\theta = \theta_H|e_H^*] = 1$
 $\mu(\theta_L|e_L^*) = \mathbb{P}[\theta = \theta_L|e_L^*] = 1$
 - $\mu^*(\theta_H|e) = \begin{cases} 1, & e = e_H^* \\ 0, & e \neq e_H^* \end{cases}$
 - $w^*(e) = \begin{cases} 3, & e = e_H^* \\ 1, & e \neq e_H^* \end{cases}$
 - $e_H^* - e_L^* \geq 2$
 - $e_H^* - e_L^* \leq 6 \Rightarrow e_H^* - e_L^* \in [2, 6]$
 - $e_L^* = 0$ is the cost-minimizing effort.
 - $\{e_H^* \in [2, 6], e_L^* = 0, w^*(e), \mu^*(\theta_H|e)\}$

PS11, Ex. 6.a: Spence's education signaling model (separating PBE)

(a) Find a separating pure strategy Perfect Bayesian Equilibrium.

- Step 1: Specify on-equilibrium path beliefs (determined by Bayes' rule). Types: $\theta \in \{\theta_L, \theta_H\}$, $\theta_H = 3$ and $\theta_L = 1$
 Prob.: $p_H = \mathbb{P}[\theta = \theta_H]$ and $p_L = 1 - p_H$
- Step 2: Specify off-equilibrium path beliefs where any deviation is believed to be by a low type. Wage: $w(e) = \mathbb{E}[\theta|e]$
 Cost: $c_\theta(e) = e/\theta$
- Step 3: Write up the wage function under competition (implied by the beliefs). Utility: $u_\theta(e) = w(e) - c_\theta(e)$
- Step 4: Find e_H^*, e_L^* such that low types will not imitate high types (ICC - Incentive Compatibility Constraint). 1. $\mu(\theta_H|e_H^*) = \mathbb{P}[\theta = \theta_H|e_H^*] = 1$
 $\mu(\theta_L|e_L^*) = \mathbb{P}[\theta = \theta_L|e_L^*] = 1$
- Step 5: Find e_H^*, e_L^* such that high types will not deviate (ICC): 2. $\mu^*(\theta_H|e) = \begin{cases} 1, & e = e_H^* \\ 0, & e \neq e_H^* \end{cases}$
- Step 6: Which level of e_L^* does θ_L choose? 3. $w^*(e) = \begin{cases} 3, & e = e_H^* \\ 1, & e \neq e_H^* \end{cases}$
- The productivity, and thus the wage, is the same for all levels of education when the incentives (ICCs) are satisfied. But education is costly for the worker. 4. $e_H^* - e_L^* \geq 2$
5. $e_H^* - e_L^* \leq 6 \Rightarrow e_H^* - e_L^* \in [2, 6]$
6. $e_L^* = 0$ is the cost-minimizing effort.
7. $\{e_H^* \in [2, 6], e_L^* = 0, w^*(e), \mu^*(\theta_H|e)\}$
- Step 7: Write up the PBE given beliefs. 8. The efficient PBE is for $e_H^* = 2$.
- Step 8: Which e_H^* is cost-minimizing?

(b) Find a pooling pure strategy Perfect Bayesian Equilibrium.

Types: $\theta \in \{\theta_L, \theta_H\}$, $\theta_H = 3$ and $\theta_L = 1$

Prob.: $p_H = \mathbb{P}[\theta = \theta_H]$ and $p_L = 1 - p_H$

Wage: $w(e) = \mathbb{E}[\theta|e]$

Cost: $c_\theta(e) = e/\theta$

Utility: $u_\theta(e) = w(e) - c_\theta(e)$

(b) Find a pooling pure strategy Perfect Bayesian Equilibrium.

Step 1: **Specify on-equilibrium path beliefs (determined by Bayes' rule) for the pooling PBE where $e_L = e_H = e_p^*$.**

Types: $\theta \in \{\theta_L, \theta_H\}$, $\theta_H = 3$ and $\theta_L = 1$
 Prob.: $p_H = \mathbb{P}[\theta = \theta_H]$ and $p_L = 1 - p_H$
 Wage: $w(e) = \mathbb{E}[\theta|e]$
 Cost: $c_\theta(e) = e/\theta$
 Utility: $u_\theta(e) = w(e) - c_\theta(e)$

(b) Find a pooling pure strategy Perfect Bayesian Equilibrium.

- Step 1: Specify on-equilibrium path beliefs (determined by Bayes' rule) for the pooling PBE where $e_L = e_H = e_p^*$.
- Types: $\theta \in \{\theta_L, \theta_H\}$, $\theta_H = 3$ and $\theta_L = 1$
 Prob.: $p_H = \mathbb{P}[\theta = \theta_H]$ and $p_L = 1 - p_H$
 Wage: $w(e) = \mathbb{E}[\theta|e]$
- Step 2: **Specify off-equilibrium path beliefs, believing any deviation is by θ_L .**
- Cost: $c_\theta(e) = e/\theta$
 Utility: $u_\theta(e) = w(e) - c_\theta(e)$
- $\mu(\theta_H|e_p^*) = p_H$, $\mu(\theta_L|e_p^*) = 1 - p_H$

(b) Find a pooling pure strategy Perfect Bayesian Equilibrium.

Step 1: Specify on-equilibrium path beliefs (determined by Bayes' rule) for the pooling PBE where $e_L = e_H = e_p^*$.

Step 2: Specify off-equilibrium path beliefs, believing any deviation is by θ_L .

Types: $\theta \in \{\theta_L, \theta_H\}$, $\theta_H = 3$ and $\theta_L = 1$

Prob.: $p_H = \mathbb{P}[\theta = \theta_H]$ and $p_L = 1 - p_H$

Wage: $w(e) = \mathbb{E}[\theta|e]$

Cost: $c_\theta(e) = e/\theta$

Utility: $u_\theta(e) = w(e) - c_\theta(e)$

$$1. \mu(\theta_H|e_p^*) = p_H, \mu(\theta_L|e_p^*) = 1 - p_H$$

$$2. \mu_p^*(\theta_H|e) = \begin{cases} p_H, & e = e_p^* \\ 0, & e \neq e_p^* \end{cases}$$

(b) Find a pooling pure strategy Perfect Bayesian Equilibrium.

- Step 1: Specify on-equilibrium path beliefs (determined by Bayes' rule) for the pooling PBE where $e_L = e_H = e_p^*$.
- Step 2: Specify off-equilibrium path beliefs, believing any deviation is by θ_L .
- Step 3: **Write up the wage function under competition (implied by the beliefs).**
- Types: $\theta \in \{\theta_L, \theta_H\}$, $\theta_H = 3$ and $\theta_L = 1$
- Prob.: $p_H = \mathbb{P}[\theta = \theta_H]$ and $p_L = 1 - p_H$
- Wage: $w(e) = \mathbb{E}[\theta|e]$
- Cost: $c_\theta(e) = e/\theta$
- Utility: $u_\theta(e) = w(e) - c_\theta(e)$
- $\mu(\theta_H|e_p^*) = p_H$, $\mu(\theta_L|e_p^*) = 1 - p_H$
 - $\mu_p^*(\theta_H|e) = \begin{cases} p_H, & e = e_p^* \\ 0, & e \neq e_p^* \end{cases}$

(b) Find a pooling pure strategy Perfect Bayesian Equilibrium.

Step 1: Specify on-equilibrium path beliefs (determined by Bayes' rule) for the pooling PBE where $e_L = e_H = e_p^*$.

Types: $\theta \in \{\theta_L, \theta_H\}$, $\theta_H = 3$ and $\theta_L = 1$

Prob.: $p_H = \mathbb{P}[\theta = \theta_H]$ and $p_L = 1 - p_H$

Wage: $w(e) = \mathbb{E}[\theta|e]$

Step 2: Specify off-equilibrium path beliefs, believing any deviation is by θ_L .

Cost: $c_\theta(e) = e/\theta$

Step 3: Write up the wage function under competition (implied by the beliefs).

Utility: $u_\theta(e) = w(e) - c_\theta(e)$

$$1. \mu(\theta_H|e_p^*) = p_H, \mu(\theta_L|e_p^*) = 1 - p_H$$

$$2. \mu_p^*(\theta_H|e) = \begin{cases} p_H, & e = e_p^* \\ 0, & e \neq e_p^* \end{cases}$$

$$3. w_p^*(e) = \begin{cases} 1 + 2p_H, & e = e_p^* \\ 1, & e \neq e_p^* \end{cases}$$

(b) Find a pooling pure strategy Perfect Bayesian Equilibrium.

- | | |
|--------------------------------------------------------------------------------------------------------------------------------------------------------------------------------------|----------------------------------------------------------------------------------------------------------------------------------------------------------------------------------------------------------------------------------------------------------------------------------------------------------------------------------------------------------------------|
| <p>Step 1: Specify on-equilibrium path beliefs (determined by Bayes' rule) for the pooling PBE where $e_L = e_H = e_p^*$.</p> | <p>Types: $\theta \in \{\theta_L, \theta_H\}$, $\theta_H = 3$ and $\theta_L = 1$
 Prob.: $p_H = \mathbb{P}[\theta = \theta_H]$ and $p_L = 1 - p_H$
 Wage: $w(e) = \mathbb{E}[\theta e]$
 Cost: $c_\theta(e) = e/\theta$</p> |
| <p>Step 2: Specify off-equilibrium path beliefs, believing any deviation is by θ_L.</p> | <p>Utility: $u_\theta(e) = w(e) - c_\theta(e)$</p> |
| <p>Step 3: Write up the wage function under competition (implied by the beliefs).</p> | <p>1. $\mu(\theta_H e_p^*) = p_H$, $\mu(\theta_L e_p^*) = 1 - p_H$</p> |
| <p>Step 4: Find e_p^* where the optimal deviation $e' = 0$ isn't profitable for θ_L (ICC - Incentive Compatibility Constraint).</p> | <p>2. $\mu_p^*(\theta_H e) = \begin{cases} p_H, & e = e_p^* \\ 0, & e \neq e_p^* \end{cases}$</p> <p>3. $w_p^*(e) = \begin{cases} 1 + 2p_H, & e = e_p^* \\ 1, & e \neq e_p^* \end{cases}$</p> |

PS11, Ex. 6.b: Spence's education signaling model (pooling PBE)

(b) Find a pooling pure strategy Perfect Bayesian Equilibrium.

Step 1: Specify on-equilibrium path beliefs (determined by Bayes' rule) for the pooling PBE where $e_L = e_H = e_p^*$.

Types: $\theta \in \{\theta_L, \theta_H\}$, $\theta_H = 3$ and $\theta_L = 1$

Prob.: $p_H = \mathbb{P}[\theta = \theta_H]$ and $p_L = 1 - p_H$

Step 2: Specify off-equilibrium path beliefs, believing any deviation is by θ_L .

Wage: $w(e) = \mathbb{E}[\theta|e]$

Cost: $c_\theta(e) = e/\theta$

Step 3: Write up the wage function under competition (implied by the beliefs).

Utility: $u_\theta(e) = w(e) - c_\theta(e)$

Step 4: Find e_p^* where the optimal deviation $e' = 0$ isn't profitable for θ_L (ICC - Incentive Compatibility Constraint):

$$1. \mu(\theta_H|e_p^*) = p_H, \mu(\theta_L|e_p^*) = 1 - p_H$$

$$2. \mu^*(\theta_H|e) = \begin{cases} p_H, & e = e_p^* \\ 0, & e \neq e_p^* \end{cases}$$

$$3. w^*(e) = \begin{cases} 1 + 2p_H, & e = e_p^* \\ 1, & e \neq e_p^* \end{cases}$$

$$4. e_p^* \leq 2p_H (*)$$

$$w(e_p^*) - c_{\theta_L}(e_p^*) \geq w(e') - c_{\theta_L}(e')$$

$$1 + 2p_H - \frac{e_p^*}{\theta_L} \geq 1 - \frac{e'}{\theta_L}$$

$$2p_H - \frac{e_p^*}{1} \geq \frac{0}{1}$$

$$2p_H \geq e_p^*$$

Step 5: Find e_p^* such that ICC holds for θ_H .

PS11, Ex. 6.b: Spence's education signaling model (pooling PBE)

(b) Find a pooling pure strategy Perfect Bayesian Equilibrium.

Step 1: Specify on-equilibrium path beliefs (determined by Bayes' rule) for the pooling PBE where $e_L = e_H = e_p^*$.

Step 2: Specify off-equilibrium path beliefs, believing any deviation is by θ_L .

Step 3: Write up the wage function under competition (implied by the beliefs).

Step 4: Find e_p^* where the optimal deviation $e' = 0$ isn't profitable for θ_L (ICC - Incentive Compatibility Constraint).

Step 5: Find e_p^* such that ICC holds for θ_H :

$$w(e_p^*) - c_{\theta_H}(e_p^*) \geq w(e') - c_{\theta_H}(e')$$

$$1 + 2p_H - \frac{e_p^*}{\theta_H} \geq 1 - \frac{e'}{\theta_H}$$

$$2p_H - \frac{e_p^*}{3} \geq \frac{0}{3}$$

$$2p_H \geq \frac{e_p^*}{3}$$

$$6p_H \geq e_p^*$$

Types: $\theta \in \{\theta_L, \theta_H\}$, $\theta_H = 3$ and $\theta_L = 1$

Prob.: $p_H = \mathbb{P}[\theta = \theta_H]$ and $p_L = 1 - p_H$

Wage: $w(e) = \mathbb{E}[\theta|e]$

Cost: $c_\theta(e) = e/\theta$

Utility: $u_\theta(e) = w(e) - c_\theta(e)$

$$1. \mu(\theta_H|e_p^*) = p_H, \mu(\theta_L|e_p^*) = 1 - p_H$$

$$2. \mu^*(\theta_H|e) = \begin{cases} p_H, & e = e_p^* \\ 0, & e \neq e_p^* \end{cases}$$

$$3. w^*(e) = \begin{cases} 1 + 2p_H, & e = e_p^* \\ 1, & e \neq e_p^* \end{cases}$$

$$4. e_p^* \leq 2p_H (*)$$

$$5. e_p^* \leq 6p_H (**) \text{ binds less than } (*).$$

PS11, Ex. 6.b: Spence's education signaling model (pooling PBE)

(b) Find a pooling pure strategy Perfect Bayesian Equilibrium.

- | | |
|--------------------------------------------------------------------------------------------------------------------------------------------------------------------------------------------------------------------------------------------------------------------------------------------------------------------------------------------------------------------------------------------------------------------------------------------------------------------------------------------------------------------------------------------------------------------------------------------------------------------------------------------------------------|---------------------------------------------------------------------------------------------------------------------------------------------------------------------------------------------------------------------------------------------------------------------------------------------------------------------------------------------------------------------------------------------------------------------------------------------------------------------------------------------------------------------------------------------------------------------------------------------------------------------------------------------------------------------------------------------------------------------------------------------------------------------------------------------------------------------------------------------------------------------------|
| <p>Step 1: Specify on-equilibrium path beliefs (determined by Bayes' rule) for the pooling PBE where $e_L = e_H = e_p^*$.</p> <p>Step 2: Specify off-equilibrium path beliefs, believing any deviation is by θ_L.</p> <p>Step 3: Write up the wage function under competition (implied by the beliefs).</p> <p>Step 4: Find e_p^* where the optimal deviation $e' = 0$ isn't profitable for θ_L (ICC - Incentive Compatibility Constraint).</p> <p>Step 5: Find e_p^* such that ICC holds for θ_H.</p> <p>Step 6: Write up the pooling PBE.</p> | <p>Types: $\theta \in \{\theta_L, \theta_H\}$, $\theta_H = 3$ and $\theta_L = 1$</p> <p>Prob.: $p_H = \mathbb{P}[\theta = \theta_H]$ and $p_L = 1 - p_H$</p> <p>Wage: $w(e) = \mathbb{E}[\theta e]$</p> <p>Cost: $c_\theta(e) = e/\theta$</p> <p>Utility: $u_\theta(e) = w(e) - c_\theta(e)$</p> <ol style="list-style-type: none"> $\mu(\theta_H e_p^*) = p_H$, $\mu(\theta_L e_p^*) = 1 - p_H$ $\mu_p^*(\theta_H e) = \begin{cases} p_H, & e = e_p^* \\ 0, & e \neq e_p^* \end{cases}$ $w_p^*(e) = \begin{cases} 1 + 2p_H, & e = e_p^* \\ 1, & e \neq e_p^* \end{cases}$ $e_p^* \leq 2p_h$ (*) $e_p^* \leq 6p_h$ (**) binds less than (*). |
|--------------------------------------------------------------------------------------------------------------------------------------------------------------------------------------------------------------------------------------------------------------------------------------------------------------------------------------------------------------------------------------------------------------------------------------------------------------------------------------------------------------------------------------------------------------------------------------------------------------------------------------------------------------|---------------------------------------------------------------------------------------------------------------------------------------------------------------------------------------------------------------------------------------------------------------------------------------------------------------------------------------------------------------------------------------------------------------------------------------------------------------------------------------------------------------------------------------------------------------------------------------------------------------------------------------------------------------------------------------------------------------------------------------------------------------------------------------------------------------------------------------------------------------------------|

PS11, Ex. 6.b: Spence's education signaling model (pooling PBE)

(b) Find a pooling pure strategy Perfect Bayesian Equilibrium.

- | | |
|--------------------------------------------------------------------------------------------------------------------------------------------------------------------------------------------------------------------------------------------------------------------------------------------------------------------------------------------------------------------------------------------------------------------------------------------------------------------------------------------------------------------------------------------------------------------------------------------------------------------------------------------------------------------------------------------------------------------------|--------------------------------------------------------------------------------------------------------------------------------------------------------------------------------------------------------------------------------------------------------------------------------------------------------------------------------------------------------------------------------------------------------------------------------------------------------------------------------------------------------------------------------------------------------------------------------------------------------------------------------------------------------------------------------------------------------------------------------------------------------------------------------------------------------------------------------------------------------------------------------------------------------------------------------------------------------------------------|
| <p>Step 1: Specify on-equilibrium path beliefs (determined by Bayes' rule) for the pooling PBE where $e_L = e_H = e_p^*$.</p> <p>Step 2: Specify off-equilibrium path beliefs, believing any deviation is by θ_L.</p> <p>Step 3: Write up the wage function under competition (implied by the beliefs).</p> <p>Step 4: Find e_p^* where the optimal deviation $e' = 0$ isn't profitable for θ_L (ICC - Incentive Compatibility Constraint).</p> <p>Step 5: Find e_p^* such that ICC holds for θ_H:</p> <p>Step 6: Write up the pooling PBE.</p> <p>Step 7: Which e_p^* is cost-minimizing?</p> | <p>Types: $\theta \in \{\theta_L, \theta_H\}$, $\theta_H = 3$ and $\theta_L = 1$</p> <p>Prob.: $p_H = \mathbb{P}[\theta = \theta_H]$ and $p_L = 1 - p_H$</p> <p>Wage: $w(e) = \mathbb{E}[\theta e]$</p> <p>Cost: $c_\theta(e) = e/\theta$</p> <p>Utility: $u_\theta(e) = w(e) - c_\theta(e)$</p> <ol style="list-style-type: none"> 1. $\mu(\theta_H e_p^*) = p_H$, $\mu(\theta_L e_p^*) = 1 - p_H$ 2. $\mu_p^*(\theta_H e) = \begin{cases} p_H, & e = e_p^* \\ 0, & e \neq e_p^* \end{cases}$ 3. $w_p^*(e) = \begin{cases} 1 + 2p_H, & e = e_p^* \\ 1, & e \neq e_p^* \end{cases}$ 4. $e_p^* \leq 2p_h$ (*) 5. $e_p^* \leq 6p_h$ (**) binds less than (*). 6. $\{e_p^* \in [0, 2p_H], w_p^*(e), \mu_p^*(\theta_H e)\}$ |
|--------------------------------------------------------------------------------------------------------------------------------------------------------------------------------------------------------------------------------------------------------------------------------------------------------------------------------------------------------------------------------------------------------------------------------------------------------------------------------------------------------------------------------------------------------------------------------------------------------------------------------------------------------------------------------------------------------------------------|--------------------------------------------------------------------------------------------------------------------------------------------------------------------------------------------------------------------------------------------------------------------------------------------------------------------------------------------------------------------------------------------------------------------------------------------------------------------------------------------------------------------------------------------------------------------------------------------------------------------------------------------------------------------------------------------------------------------------------------------------------------------------------------------------------------------------------------------------------------------------------------------------------------------------------------------------------------------------|

PS11, Ex. 6.b: Spence's education signaling model (pooling PBE)

(b) Find a pooling pure strategy Perfect Bayesian Equilibrium.

- | | |
|---------------------------------------------------------------------------------------------------------------------------------------|-----------------------------------------------------------------------------------------------------------------------------------------------------------------------------------------------------------------------------|
| Step 1: Specify on-equilibrium path beliefs (determined by Bayes' rule) for the pooling PBE where $e_L = e_H = e_p^*$. | Types: $\theta \in \{\theta_L, \theta_H\}$, $\theta_H = 3$ and $\theta_L = 1$
Prob.: $p_H = \mathbb{P}[\theta = \theta_H]$ and $p_L = 1 - p_H$
Wage: $w(e) = \mathbb{E}[\theta e]$
Cost: $c_\theta(e) = e/\theta$ |
| Step 2: Specify off-equilibrium path beliefs, believing any deviation is by θ_L . | Utility: $u_\theta(e) = w(e) - c_\theta(e)$ |
| Step 3: Write up the wage function under competition (implied by the beliefs). | 1. $\mu(\theta_H e_p^*) = p_H$, $\mu(\theta_L e_p^*) = 1 - p_H$ |
| Step 4: Find e_p^* where the optimal deviation $e' = 0$ isn't profitable for θ_L (ICC - Incentive Compatibility Constraint). | 2. $\mu_p^*(\theta_H e) = \begin{cases} p_H, & e = e_p^* \\ 0, & e \neq e_p^* \end{cases}$ |
| Step 5: Find e_p^* such that ICC holds for θ_H : | 3. $w_p^*(e) = \begin{cases} 1 + 2p_H, & e = e_p^* \\ 1, & e \neq e_p^* \end{cases}$ |
| Step 6: Write up the pooling PBE. | 4. $e_p^* \leq 2p_h$ (*) |
| Step 7: Which e_p^* is cost-minimizing? | 5. $e_p^* \leq 6p_h$ (**) binds less than (*). |
| | 6. $\{e_p^* \in [0, 2p_H], w_p^*(e), \mu_p^*(\theta_H e)\}$ |
| | 7. The efficient PBE is for $e_p^* = 0$. |

PS11, Ex. 6.b: Spence's education signaling model (pooling PBE)

(b) Find a pooling pure strategy Perfect Bayesian Equilibrium.

- | | |
|---------------------------------------------------------------------------------------------------------------------------------------------|--------------------------------------------------------------------------------------------|
| Step 1: Specify on-equilibrium path beliefs (determined by Bayes' rule) for the pooling PBE where $e_L = e_H = e_p^*$. | Types: $\theta \in \{\theta_L, \theta_H\}$, $\theta_H = 3$ and $\theta_L = 1$ |
| Step 2: Specify off-equilibrium path beliefs, believing any deviation is by θ_L . | Prob.: $p_H = \mathbb{P}[\theta = \theta_H]$ and $p_L = 1 - p_H$ |
| Step 3: Write up the wage function under competition (implied by the beliefs). | Wage: $w(e) = \mathbb{E}[\theta e]$ |
| Step 4: Find e_p^* where the optimal deviation $e' = 0$ isn't profitable for θ_L (ICC - Incentive Compatibility Constraint). | Cost: $c_\theta(e) = e/\theta$ |
| Step 5: Find e_p^* such that ICC holds for θ_H . | Utility: $u_\theta(e) = w(e) - c_\theta(e)$ |
| Step 6: Write up the pooling PBE. | 1. $\mu(\theta_H e_p^*) = p_H$, $\mu(\theta_L e_p^*) = 1 - p_H$ |
| Step 7: Which e_p^* is cost-minimizing? | 2. $\mu_p^*(\theta_H e) = \begin{cases} p_H, & e = e_p^* \\ 0, & e \neq e_p^* \end{cases}$ |
| Step 8: Explain: Which 2 assumptions are necessary for this PBE where both high-ability and low-ability workers take zero education? | 3. $w_p^*(e) = \begin{cases} 1 + 2p_H, & e = e_p^* \\ 1, & e \neq e_p^* \end{cases}$ |
| | 4. $e_p^* \leq 2p_h$ (*) |
| | 5. $e_p^* \leq 6p_h$ (**) binds less than (*). |
| | 6. $\{e_p^* \in [0, 2p_H], w_p^*(e), \mu_p^*(\theta_H e)\}$ |
| | 7. The efficient PBE is for $e_p^* = 0$. |

PS11, Ex. 6.b: Spence's education signaling model (pooling PBE)

(b) Find a pooling pure strategy Perfect Bayesian Equilibrium.

Step 1: Specify on-equilibrium path beliefs (determined by Bayes' rule) for the pooling PBE where $e_L = e_H = e_p^*$.

Step 8: Explain: Which 2 assumptions are necessary for this PBE where both high-ability and low-ability workers take zero education?

8.i Education is unproductive, thus, it only affects the wage in terms of being a signal of one's type.

8.ii The firm believes that any deviation from the pooling eq. would be by a low ability type.

[Bonus] Can a pooling PBE exist with beliefs that a certain deviation e'' is believed to be by a high type θ_H ?

Types: $\theta \in \{\theta_L, \theta_H\}$, $\theta_H = 3$ and $\theta_L = 1$

Prob.: $p_H = \mathbb{P}[\theta = \theta_H]$ and $p_L = 1 - p_H$

Wage: $w(e) = \mathbb{E}[\theta|e]$

Cost: $c_\theta(e) = e/\theta$

Utility: $u_\theta(e) = w(e) - c_\theta(e)$

$$1. \mu(\theta_H|e_p^*) = p_H, \mu(\theta_L|e_p^*) = 1 - p_H$$

$$2. \mu_p^*(\theta_H|e) = \begin{cases} p_H, & e = e_p^* \\ 0, & e \neq e_p^* \end{cases}$$

$$3. w_p^*(e) = \begin{cases} 1 + 2p_H, & e = e_p^* \\ 1, & e \neq e_p^* \end{cases}$$

$$4. e_p^* \leq 2p_H (*)$$

$$5. e_p^* \leq 6p_H (**) \text{ binds less than } (*).$$

$$6. \{e_p^* \in [0, 2p_H], w_p^*(e), \mu_p^*(\theta_H|e)\}$$

$$7. \text{The efficient PBE is for } e_p^* = 0.$$

(b) Find a pooling pure strategy Perfect Bayesian Equilibrium.

Step 1: Specify on-equilibrium path beliefs (determined by Bayes' rule) for the pooling PBE where $e_L = e_H = e_p^*$.

Step 8: Explain: Which 2 assumptions are necessary for this PBE where both type θ_H and θ_L take zero education?

[Bonus] Can a pooling PBE exist with beliefs that a certain deviation e'' is believed to be by a high type θ_H ?

Step 9: **Specify off-equilibrium path beliefs and the wage function.**

1. $\mu(\theta_H|e_p^*) = p_H, \mu(\theta_L|e_p^*) = 1 - p_H$
4. $e_p^* \leq 2p_h$ (*)
5. $e_p^* \leq 6p_h$ (**) binds less than (*).
6. $\{e_p^* \in [0, 2p_H], w_p^*(e), \mu_p^*(\theta_H|e)\}$
 - 8.i Education is unproductive, thus, it only affects the wage in terms of being a signal of one's type.
 - 8.ii The firm believes that any deviation from the pooling eq. would be by a low ability type.

PS11, Ex. 6.b: Spence's education signaling model (pooling PBE)

(b) Find a pooling pure strategy Perfect Bayesian Equilibrium.

Step 1: Specify on-equilibrium path beliefs (determined by Bayes' rule) for the pooling PBE where $e_L = e_H = e_p^*$.

Step 8: Explain: Which 2 assumptions are necessary for this PBE where both type θ_H and θ_L take zero education?

[Bonus] Can a pooling PBE exist with beliefs that a certain deviation e'' is believed to be by a high type θ_H ?

Step 9: Specify off-equilibrium path beliefs.

Step 10: **Write up the implied wage function.**

$$1. \mu(\theta_H|e_p^*) = p_H, \mu(\theta_L|e_p^*) = 1 - p_H$$

$$4. e_p^* \leq 2p_h (*)$$

$$5. e_p^* \leq 6p_h (**) \text{ binds less than } (*).$$

$$6. \{e_p^* \in [0, 2p_H], w_p^*(e), \mu_p^*(\theta_H|e)\}$$

8.i Education is unproductive, thus, it only affects the wage in terms of being a signal of one's type.

8.ii The firm believes that any deviation from the pooling eq. would be by a low ability type.

$$9. \mu_p^{**}(\theta_H) = \begin{cases} 1, & e = e'' \\ p_H, & e = e_p^{**} \\ 0, & e \notin \{e_p^{**}, e''\} \end{cases}$$

PS11, Ex. 6.b: Spence's education signaling model (pooling PBE)

(b) Find a pooling pure strategy Perfect Bayesian Equilibrium.

Step 1: Specify on-equilibrium path beliefs (determined by Bayes' rule) for the pooling PBE where $e_L = e_H = e_p^*$.

Step 8: Explain: Which 2 assumptions are necessary for this PBE where both type θ_H and θ_L take zero education?

[Bonus] Can a pooling PBE exist with beliefs that a certain deviation e'' is believed to be by a high type θ_H ?

Step 9: Specify off-equilibrium path beliefs.

Step 10: Write up the implied wage function.

Step 11: **While the ICCs (*), (**) still hold, find e_p^{**} , e'' such that it's not profitable for θ_L to deviate to e'' .**

$$1. \mu(\theta_H|e_p^*) = p_H, \mu(\theta_L|e_p^*) = 1 - p_H$$

$$4. e_p^* \leq 2p_h (*)$$

$$5. e_p^* \leq 6p_h (**) \text{ binds less than } (*).$$

$$6. \{e_p^* \in [0, 2p_H], w_p^*(e), \mu_p^*(\theta_H|e)\}$$

8.i Education is unproductive, thus, it only affects the wage in terms of being a signal of one's type.

8.ii The firm believes that any deviation from the pooling eq. would be by a low ability type.

$$9. \mu_p^{**}(\theta_H) = \begin{cases} 1, & e = e'' \\ p_H, & e = e_p^{**} \\ 0, & e \notin \{e_p^{**}, e''\} \end{cases}$$

$$10. w_p^{**} = \begin{cases} 3, & e = e'' \\ 1 + 2p_H, & e = e_p^{**} \\ 1, & e \notin \{e_p^{**}, e''\} \end{cases}$$

PS11, Ex. 6.b: Spence's education signaling model (pooling PBE)

(b) Find a pooling pure strategy Perfect Bayesian Equilibrium.

Step 1: Specify on-equilibrium path beliefs (determined by Bayes' rule) for the pooling PBE where $e_L = e_H = e_p^*$.

Step 8: Explain: Which 2 assumptions are necessary for this PBE where both type θ_H and θ_L take zero education?

[Bonus] Can a pooling PBE exist with beliefs that a certain deviation e'' is believed to be by a high type θ_H ?

Step 9: Specify off-equilibrium path beliefs.

Step 10: Write up the implied wage function.

Step 11: While the ICCs (*), (**) still hold, find e_p^{**} , e'' such that it's not profitable for θ_L to deviate to e'' :

$$w(e_p^{**}) - c_{\theta_L}(e_p^{**}) \geq w(e'') - c_{\theta_L}(e'')$$

$$1 + 2p_H - \frac{e_p^{**}}{1} \geq 3 - \frac{e''}{1}$$

$$2p_H - e_p^{**} \geq 2 - e''$$

$$e'' \geq 2 - 2p_H + e_p^{**}$$

Step 12: **Also, θ_H must not deviate to e'' .**

$$1. \mu(\theta_H | e_p^*) = p_H, \mu(\theta_L | e_p^*) = 1 - p_H$$

$$4. e_p^* \leq 2p_H (*)$$

$$5. e_p^* \leq 6p_H (**) \text{ binds less than } (*).$$

$$6. \{e_p^* \in [0, 2p_H], w_p^*(e), \mu_p^*(\theta_H | e)\}$$

8.i Education is unproductive, thus, it only affects the wage in terms of being a signal of one's type.

8.ii The firm believes that any deviation from the pooling eq. would be by a low ability type.

$$9. \mu_p^{**}(\theta_H) = \begin{cases} 1, & e = e'' \\ p_H, & e = e_p^{**} \\ 0, & e \notin \{e_p^{**}, e''\} \end{cases}$$

$$10. w_p^{**} = \begin{cases} 3, & e = e'' \\ 1 + 2p_H, & e = e_p^{**} \\ 1, & e \notin \{e_p^{**}, e''\} \end{cases}$$

$$11. e'' \geq 2 - 2p_H + e_p^{**} (\dagger)$$

PS11, Ex. 6.b: Spence's education signaling model (pooling PBE)

(b) Find a pooling pure strategy Perfect Bayesian Equilibrium.

Step 1: Specify on-equilibrium path beliefs (determined by Bayes' rule) for the pooling PBE where $e_L = e_H = e_p^*$.

Step 8: Explain: Which 2 assumptions are necessary for this PBE where both type θ_H and θ_L take zero education?
 [Bonus] Can a pooling PBE exist with beliefs that a certain deviation e'' is believed to be by a high type θ_H ?

Step 9: Specify off-equilibrium path beliefs.

Step 10: Write up the implied wage function.

Step 11: While the ICCs (*), (**) still hold, find e_p^{**}, e'' such that it's not profitable for θ_L to deviate to e'' .

Step 12: Also, θ_H must not deviate to e'' :
 $w(e_p^{**}) - c_{\theta_H}(e_p^{**}) \geq w(e'') - c_{\theta_H}(e'')$

$$1 + 2p_H - \frac{e_p^{**}}{3} \geq 3 - \frac{e''}{3}$$

$$\frac{e''}{3} \geq 2 - 2p_H + \frac{e_p^{**}}{3}$$

$$e'' \geq 6 - 6p_H + e_p^{**}$$

$$1. \mu(\theta_H|e_p^*) = p_H, \mu(\theta_L|e_p^*) = 1 - p_H$$

$$4. e_p^* \leq 2p_h (*)$$

$$5. e_p^* \leq 6p_h (**) \text{ binds less than } (*).$$

$$6. \{e_p^* \in [0, 2p_H], w_p^*(e), \mu_p^*(\theta_H|e)\}$$

8.i Education is unproductive, thus, it only affects the wage in terms of being a signal of one's type.

8.ii The firm believes that any deviation from the pooling eq. would be by a low ability type.

$$9. \mu_p^{**}(\theta_H) = \begin{cases} 1, & e = e'' \\ p_H, & e = e_p^{**} \\ 0, & e \notin \{e_p^{**}, e''\} \end{cases}$$

$$10. w_p^{**} = \begin{cases} 3, & e = e'' \\ 1 + 2p_H, & e = e_p^{**} \\ 1, & e \notin \{e_p^{**}, e''\} \end{cases}$$

$$11. e'' \geq 2 - 2p_H + e_p^{**} (\dagger)$$

$$12. e'' \geq 6 - 6p_H + e_p^{**} (\ddagger) \text{ binds more.}$$

PS11, Ex. 6.b: Spence's education signaling model (pooling PBE)

(b) Find a pooling pure strategy Perfect Bayesian Equilibrium.

Step 1: Specify on-equilibrium path beliefs (determined by Bayes' rule) for the pooling PBE where $e_L = e_H = e_p^*$.

Step 8: Explain: Which 2 assumptions are necessary for this PBE where both type θ_H and θ_L take zero education?

[Bonus] Can a pooling PBE exist with beliefs that a certain deviation e'' is believed to be by a high type θ_H ?

Step 9: Specify off-equilibrium path beliefs.

Step 10: Write up the implied wage function.

Step 11: While the ICCs (*), (**) still hold, find e_p^{**} , e'' such that it's not profitable for θ_L to deviate to e'' .

Step 12: Also, θ_H must not deviate to e'' .

Step 13: **Write up the PBE conditional on** (‡).

$$1. \mu(\theta_H | e_p^*) = p_H, \mu(\theta_L | e_p^*) = 1 - p_H$$

$$4. e_p^* \leq 2p_h (*)$$

$$5. e_p^* \leq 6p_h (**) \text{ binds less than } (*).$$

$$6. \{e_p^* \in [0, 2p_H], w_p^*(e), \mu_p^*(\theta_H | e)\}$$

8.i Education is unproductive, thus, it only affects the wage in terms of being a signal of one's type.

8.ii The firm believes that any deviation from the pooling eq. would be by a low ability type.

$$9. \mu_p^{**}(\theta_H) = \begin{cases} 1, & e = e'' \\ p_H, & e = e_p^{**} \\ 0, & e \notin \{e_p^{**}, e''\} \end{cases}$$

$$10. w_p^{**} = \begin{cases} 3, & e = e'' \\ 1 + 2p_H, & e = e_p^{**} \\ 1, & e \notin \{e_p^{**}, e''\} \end{cases}$$

$$11. e'' \geq 2 - 2p_H + e_p^{**} (\dagger)$$

$$12. e'' \geq 6 - 6p_H + e_p^{**} (\ddagger) \text{ binds more.}$$

PS11, Ex. 6.b: Spence's education signaling model (pooling PBE)

(b) Find a pooling pure strategy Perfect Bayesian Equilibrium.

Step 1: Specify on-equilibrium path beliefs (determined by Bayes' rule) for the pooling PBE where $e_L = e_H = e_p^*$.

Step 8: Explain: Which 2 assumptions are necessary for this PBE where both type θ_H and θ_L take zero education?

[Bonus] Can a pooling PBE exist with beliefs that a certain deviation e'' is believed to be by a high type θ_H ?

Step 9: Specify off-equilibrium path beliefs.

Step 10: Write up the implied wage function.

Step 11: While the ICCs (*), (**) still hold, find e_p^{**} , e'' such that it's not profitable for θ_L to deviate to e'' .

Step 12: Also, θ_H must not deviate to e'' .

Step 13: Write up the PBE conditional on (‡):
 $\{e_L = e_H = e_p^{**} \in [0, 2p_H], w_p^{**}(e), \mu_p^{**}(\theta_H|e)\}$

Step 14: **Why would θ_H not deviate to e'' ?**

$$1. \mu(\theta_H|e_p^*) = p_H, \mu(\theta_L|e_p^*) = 1 - p_H$$

$$4. e_p^* \leq 2p_h (*)$$

$$5. e_p^* \leq 6p_h (**) \text{ binds less than } (*).$$

$$6. \{e_p^* \in [0, 2p_H], w_p^*(e), \mu_p^*(\theta_H|e)\}$$

8.i Education is unproductive, thus, it only affects the wage in terms of being a signal of one's type.

8.ii The firm believes that any deviation from the pooling eq. would be by a low ability type.

$$9. \mu_p^{**}(\theta_H) = \begin{cases} 1, & e = e'' \\ p_H, & e = e_p^{**} \\ 0, & e \notin \{e_p^{**}, e''\} \end{cases}$$

$$10. w_p^{**} = \begin{cases} 3, & e = e'' \\ 1 + 2p_H, & e = e_p^{**} \\ 1, & e \notin \{e_p^{**}, e''\} \end{cases}$$

$$11. e'' \geq 2 - 2p_H + e_p^{**} (\dagger)$$

$$12. e'' \geq 6 - 6p_H + e_p^{**} (\ddagger) \text{ binds more.}$$

PS11, Ex. 6.b: Spence's education signaling model (pooling PBE)

(b) Find a pooling pure strategy Perfect Bayesian Equilibrium.

Step 1: Specify on-equilibrium path beliefs (determined by Bayes' rule) for the pooling PBE where $e_L = e_H = e_p^*$.

Step 8: Explain: Which 2 assumptions are necessary for this PBE where both type θ_H and θ_L take zero education?

[Bonus] Can a pooling PBE exist with beliefs that a certain deviation e'' is believed to be by a high type θ_H ?

Step 9: Specify off-equilibrium path beliefs.

Step 10: Write up the implied wage function.

Step 11: While the ICCs (*), (**) still hold, find e_p^{**}, e'' such that it's not profitable for θ_L to deviate to e'' .

Step 12: Also, θ_H must not deviate to e'' .

Step 13: Write up the PBE conditional on (\ddagger): $\{e_L = e_H = e_p^{**} \in [0, 2p_H], w_p^{**}(e), \mu_p^{**}(\theta_H|e)\}$

Step 14: Why would θ_H not deviate to e'' ?
The firm requires an inefficiently high e'' in order to believe the worker is type θ_H .

$$1. \mu(\theta_H|e_p^*) = p_H, \mu(\theta_L|e_p^*) = 1 - p_H$$

$$4. e_p^* \leq 2p_H (*)$$

$$5. e_p^* \leq 6p_H (**) \text{ binds less than } (*).$$

$$6. \{e_p^* \in [0, 2p_H], w_p^*(e), \mu_p^*(\theta_H|e)\}$$

8.i Education is unproductive, thus, it only affects the wage in terms of being a signal of one's type.

8.ii The firm believes that any deviation from the pooling eq. would be by a low ability type.

$$9. \mu_p^{**}(\theta_H) = \begin{cases} 1, & e = e'' \\ p_H, & e = e_p^{**} \\ 0, & e \notin \{e_p^{**}, e''\} \end{cases}$$

$$10. w_p^{**} = \begin{cases} 3, & e = e'' \\ 1 + 2p_H, & e = e_p^{**} \\ 1, & e \notin \{e_p^{**}, e''\} \end{cases}$$

$$11. e'' \geq 2 - 2p_H + e_p^{**} (\ddagger)$$

$$12. e'' \geq 6 - 6p_H + e_p^{**} (\ddagger) \text{ binds more.}$$